

ELLIET

MANUAL

Super Prof



This booklet provides information about the actual use and maintenance of the machine. **Read it carefully and keep it in a safe place.**



Please also keep your **purchasing invoice** or receipt together with this booklet.



Register your purchase online at **www.eli.eu**

© ELIET

Copyright 2015 ELIET. All rights reserved. All textual material, drawings, illustrations, diagrams, graphs, etc., included in this ELIET booklet are protected by copyright and also by other intellectual property rights. None of this information may be copied for commercial purposes or distribution and/or changed or reposted for other purposes. The copyright on the content included in this ELIET manual remains the exclusive property of its respective owners.

1. Introduction



1.1 Carefully read this user manual

ELIET machines are designed for safe and reliable use; this requires their operation in accordance with the instructions provided. Carefully read these operating instructions before using the machine. Failure to do so may result in personal injury or damage to the equipment.

1.2 Identification data - ELIET Super Prof

Write the identification data relating to your machine in the boxed areas:

Article number:

MA

Serial number:

Year of Manufacture::

Purchase date :

2. Warranty



2.1 Registration of your machine

In order to be able to make a warranty claim, you will need to register your machine online within one month after purchase: www.elieta.eu / www.elieta.com

European customers : ELIET EUROPE NV

Diesveldstraat 2

8553 Otegem - Belgium

T (+32)(0)56 77 70 88 - **F** (+32)(0)56 77 52 13

www.elieta.eu

US customers : ELIET USA Inc.

3361 Stafford street - USA

Pittsburgh, PA 15204 - USA

T 412 367 5185 - **F** 412 774 1970

www.elietausa.com

Read the warranty conditions "16.5 Warranty-conditions" on page 82

3. Welcome



Welcome to the family of ELIET customers.

We would like to thank you for the confidence that you have placed in ELIET and we are convinced that you have purchased the very best machine. The operating life of your ELIET machine depends to a great extent on how you care for your machine. This user manual and the engine manual provided will assist you in this respect. If you follow the instructions and suggestions in these manuals, your ELIET machine will operate for a very long time in optimal condition.

Read this instruction manual carefully before operating this machine. This will prevent you from operating the device incorrectly.

For your own safety, take into account the safety instructions stated in the relevant chapter. Even if you are thoroughly familiar with operating such equipment, it is still advisable to read these pages carefully.

At ELIET all our machines and devices are subjected to a policy of continuous change and therefore, the specification of your machine may differ slightly in terms of shape, technology and accessories. The descriptions and technical data in this manual are accurate at the time of printing. Certain illustrations and descriptions may not be applicable to your specific machine, but instead relate to a different version of the machine. In turn, we trust that you will understand that the texts and illustrations in this manual cannot lead to any claims.

If you still have any questions after you have read this manual, we request you to contact your ELIET dealer.

ELIET AT YOUR SERVICE

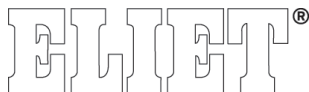

European customers GMT +1 : from 08:00 to 18:00 HRS

Zwevegstraat 136
B-8553 Otegem
Belgium

Phone : (+32) (0)56 77 70 88
Fax : (+32) (0)56 77 52 13
Email: service@eliet.be

Warning

OPERATING OUTDOOR POWER EQUIPMENT

Under the laws of several countries or states you are not permitted to operate an internal combustion engine using hydrocarbon fuels on any forest covered, brush covered or grass covered land or on land covered with grain hay or other flammable agricultural crop, without an engine spark arrester in continuous effective working order.

The engine on your power equipment, like most outdoor power equipment, is an internal combustion engine that burns gasoline, a hydrocarbon fuel. Therefore, your power equipment must be equipped with a spark arrester muffler in continuous effective working order. The spark arrester must be attached to the engine exhaust system in such a manner that flames or heat from the system will not ignite flammable material.

Failure of the owner/operator of the equipment to comply with this regulation is a misdemeanour under certain law (e.g. Californian Law), and may also be a violation of other state and or federal regulations, laws, ordinances, or codes. Contact your local fire marshal or forest service for specific information about what regulations apply in your area.

The standard muffler installed on the ELIET engines is not equipped with a spark arrester. One must be added before use if this machine is intended to be used in an area where a spark arrester is required by law. Contact the local authorities if these laws apply to you. See your authorized engine dealer for spark arrester options.

ELIET AT YOUR SERVICE



US Customers GMT +6 : 8 AM till 6 PM

Phone : 412 367 5185

Fax : 412 774 1970

service@elietmachines.com

4. Table of Contents

1. Introduction	3
1.1 Carefully read this user manual	3
1.2 Identification data - ELIET Super Prof	3
2. Warranty	3
2.1 Registration of your machine	3
3. Welcome	4
4. Table of Contents	6
5. Safety symbols	9
5.1 For your information	9
5.2 Caution	9
5.3 Warning	9
6. Main parts	10
7. Safety regulations	12
7.1 Safety messages :	12
7.2 Safety provisions	16
7.3 Safety regulations	18
7.3.1 General safety precautions	18
7.3.2 Careful and security-conscious use	18
7.3.3 Responsibilities of the Operator	19
7.3.4 Personal Protective Equipment (PPE)	20
7.3.5 Danger zone	20
7.3.6 Periodic maintenance	20
7.3.7 Respect the environment	21
8. Dealer's duties	22
9. Operating instructions	23
9.1 Preliminary checks	23
9.2 Filling up with petrol	24
9.3 Preparing the work area	25
9.4 Starting the Petrol Engine	25
9.5 Moving the machine	27
9.6 Operating the machine	29
9.6.1 Before starting work	29
9.6.2 Turning and positioning the blowchute and deflector-flap	30
9.6.3 During the work	30
9.7 Cleaning the machine	36
10. Transporting the machine	38
11. Maintenance tasks described in detail	40
11.1 General	40
11.2 General interventions	41
11.2.1 Removing the belt guard	41
11.2.2 Removing the chain guard	42
11.2.3 Disconnecting the battery	42

11.2.4	Opening the Axelero™ chamber	42
11.2.5	Opening the shredding chamber	43
11.2.6	Putting the blow chute in working or transport position	46
11.3	Engine maintenance	47
11.3.1	Checking the oil level in the engine crankcase + refilling	47
11.3.2	Engine oil change (Engine Oil)	48
11.3.3	Changing the oil filter (Oil filter)	48
11.3.4	Cleaning the air filter (Clean air filter)	49
11.3.5	Changing the air filter	49
11.3.6	Changing the engine fuel filter (Oil filter)	50
11.3.7	Changing the hydraulic oil	50
11.3.8	Changing the hydraulic oil filter (Hydraul. filter)	51
11.4	Machine maintenance	52
11.4.1	Checking the blades	52
11.4.2	Sharpening the blades	53
11.4.3	Reversing and renewing the shredding knives (Turn Knives)	55
11.4.4	Checking the drive belt for correct tension (Chk Belt Tens.)	60
11.4.5	Tightening the V-belt (Tighten belt)	61
11.4.6	Changing the belts (Replace Belts)	62
11.4.7	Checking the tension of the drive chain for the feed roller	63
11.4.8	Checking and adjusting the tracks for correct tension (Cross Country model)	63
11.4.9	General lubrication (Lubrication)	64
11.5	Maintenance schedule	68
11.5.1	Special maintenance	69
11.5.2	Daily maintenance	70
11.5.3	Maintenance after 5 hours	70
11.5.4	Maintenance after 10 hours	70
11.5.5	Maintenance after 25 hours	71
11.5.6	Maintenance after 50 hours	71
11.5.7	Maintenance after 100 hours (or six-monthly)	71
11.5.8	Maintenance after 200 hours (or annually)	72
12.	Winterizing the machine	73
13.	Options	74
13.1	Sieve screening	74
14.	Equipment specifications	75
15.	EC Declaration of Conformity	76
16.	Appendix	77
16.1	Technical specifications of the lubricants and fuel	77
16.2	List of torques	78
16.3	Troubleshooting - resolving problems	79
16.3.1	F00: Oil Press. Low	79
16.3.2	F01: Safety Cover	79
16.3.3	F02: Oil Pr. sensor	79
16.3.4	F03: Short Clutch	80
16.3.5	F04: Wiring Clutch	80

16.3.6 F05: Short FEED FWD	80
16.3.7 F06: Wiring FEED FWD	80
16.3.8 F07: Short FEED REV	80
16.3.9 F08: Wiring FEED REV	80
16.3.10 F09: Short THROTTLE	80
16.3.11 F10: Wiring THROTTLE	80
16.4 Dashboard warnings	81
16.4.1 W00: Safety Bar	81
16.4.2 W01: AntiBlock Motor	81
16.4.3 W02: Speed Up Engine	81
16.4.4 W03: Activate Blades	81
16.4.5 W04: Load Too High	81
16.4.6 W05: Start failed	81
16.5 Warranty-conditions	82

5. Safety symbols



Certain symbols in this manual are used to provide additional information and to draw your attention to potential risks.

5.1 For your information



For your information

This symbol is used to draw your attention to specific information and/or actions, or to denote where you can find additional information relating to the subject.

5.2 Caution



Caution :

This notice identifies safe usage habits. This is done to prevent incorrect actions that can result in personal injury or damage to the machine.

5.3 Warning



Warning :

This notice is used to warn you about extreme danger that you must be aware of in these specific circumstances. Thus remain alert, in order to ensure your own safety.

6. Main parts

To fully understand the content of this operator's manual, you need to be fully conversant with the terminology used for [www] the descriptions. In this chapter you can find a set of parts identified by name. It is a good idea to take time to study the machine beforehand for an improved understanding of the descriptions provided in this user manual.

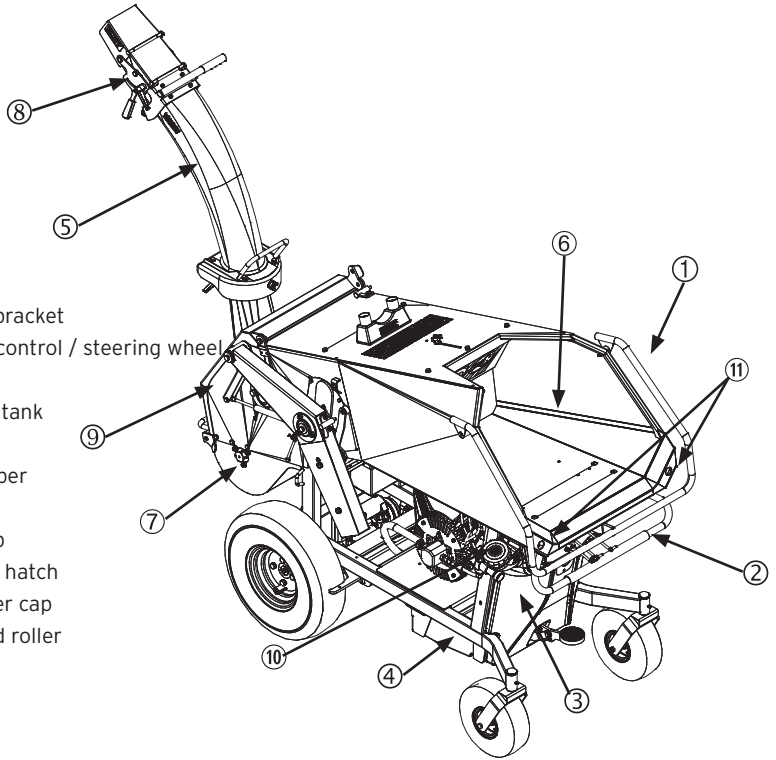

- 1) Safety-stop-bracket
- 2) Wheel drive control / steering wheel
- 3) Petrol tank
- 4) Hydraulic oil tank
- 5) Blow chute
- 6) Loading hopper
- 7) Axelero™
- 8) Deflector cap
- 9) Maintenance hatch
- 10) Fuel tank filler cap
- 11) Controls feed roller

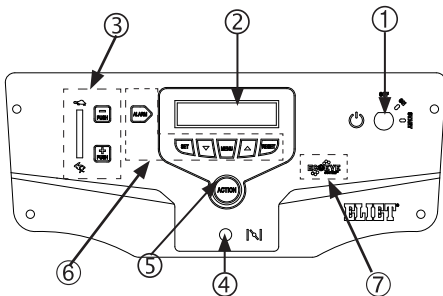

- 1) Ignition Key
- 2) LCD controle screen
- 3) Throttle
- 4) Choke
- 5) Action button
- 6) Controlbuttons Display
- 7) Eco Eye signage (optional)

- 1) Safety screen
- 2) Instrument panel
- 3) Foot brake
- 4) Feed roller
- 5) Sieve screen
- 6) Knife drum
- 7) Speed control regulator (optional)
- 8) Eco Eye sensor (optional)

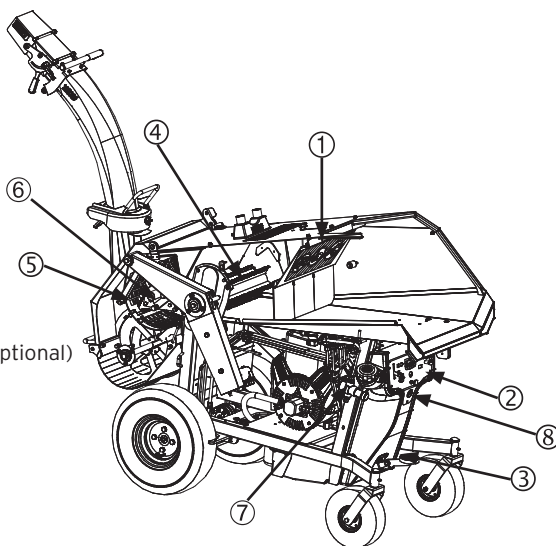

For your information :

Order number in this manual to right or left hand side, back or front of the unit is observed from the machine operator facing the branch feed of the machine.

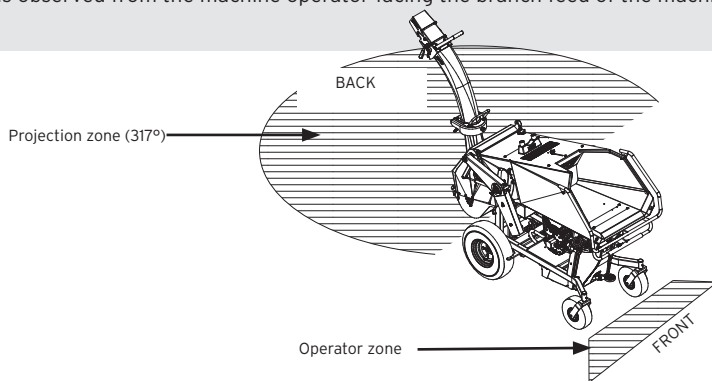

Your ELIET dealer is at your service, ready to provide you with maintenance or advice so that your ELIET machine always remains in optimal condition. You can contact him for genuine ELIET service parts and lubricants. These service parts are manufactured to the same stringent accuracy requirements and standard of craftsmanship as the original equipment.



Caution :

For your safety, use only genuine ELIET parts on ELIET machines.

7. Safety regulations



7.1 Safety messages :

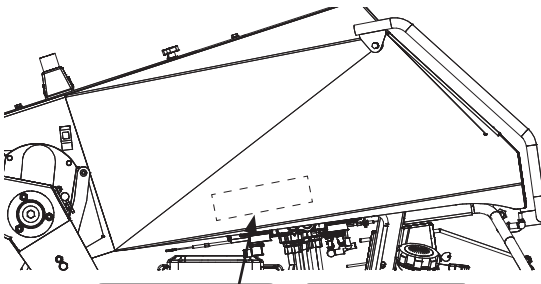

①



②

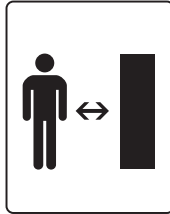

Stickers (1 en 2) are pasted on the left side of the Super Prof. Sticker (1) sums up the general safety instructions by means of icons: Read this user manual carefully in its entirety before attempting to operate this machine. Always wear the appropriate protective garment when operating the machine (protective gloves, safety goggles, hearing protectors).

Sticker (2) reminds the user to keep bystanders a safe distance away (10m). (order number: BQ 501 070 130)

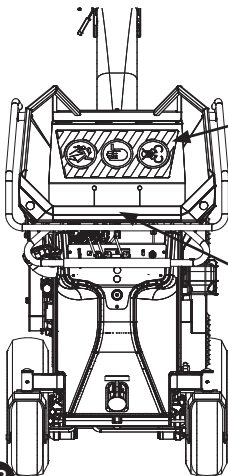

②

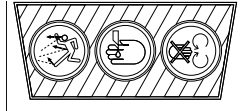

①



Sticker (1) affixed to the feed opening warns that no attempt should be made to put your hands past the safety screen. (order number: BQ 505 010 110)

While sticker (2) located on the safety screen warns the user of the danger of hand injuries and of flying debris. These are two risks - inherent in chipping branchy material - which are catered for by the safety screen.

(order number: BQ 505 010 100)

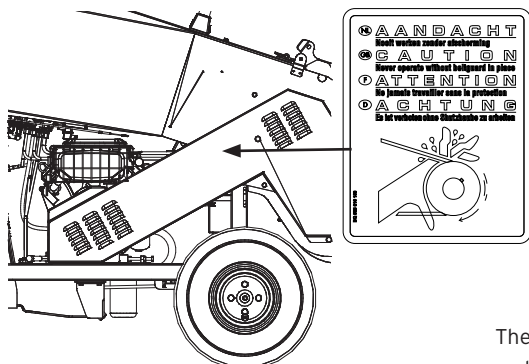

These stickers on the safety covers of both the V-belt and the chain warn the user that a V-belt or chain is fitted behind the shielding panel. It is strictly forbidden to operate the machine with the safety guards removed.

(order number: BQ 505 010 130)

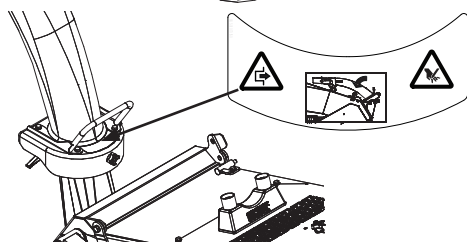

The blow chute can be folded over in order to make the unit smaller for transport.

This sticker, on the blow chute, refers the user to the fact that bending the blow chute corresponds to a risk of fingers becoming jammed or cut. The sticker also refers to disengaging the blade drive on the Axelero before bending the blow chute.

Never put your hands into the folded-out blow chute.

(order number: BQ 501 070 150)

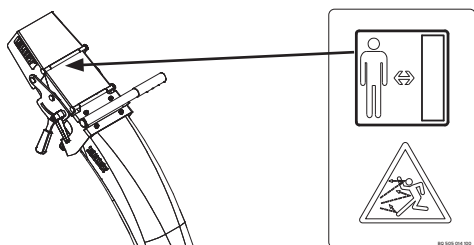

This sticker, on the blow chute flap, refers the user to the risk of flying chippings. Maintain a safe distance from the projection zone of the blow chute when the machine is being operated.

(order number: BQ 505 014 100)

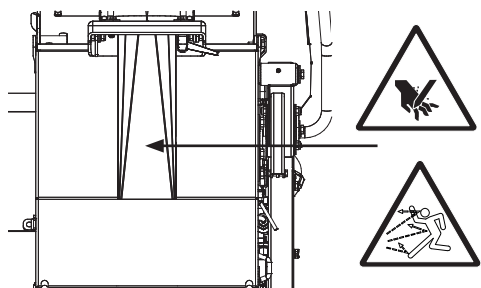

This sticker, placed above the shredder chamber, warns the user about the hazard of flying chippings and the danger of being cut by the blades when opening the maintenance hatch that provides access to the Axelero's blade system.

(order number: BQ 501 070 140)



This decal is displayed on the side of the loading hopper. The legend specifies the guaranteed A-weighted sound power level Lw(A) emission from the machine under calibrated conditions.

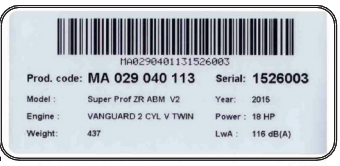

This decal is located on the side of the loading hopper. It lists all the identification data relating to the machine :

Model, model number, serial number, year of manufacture, engine, power rating, weight, guaranteed A-weighted sound power level Lw(A).

This sticker also lists the manufacturer's details. The CE label means that the machine complies with the governing European machinery directive.



Caution :

Safety stickers becoming damaged, illegible or removed through use or cleaning, must be immediately renewed. Stickers are available at your approved ELIET Dealer.

The following stickers apply exclusively to our American Customers :

CAUTION

- 1/ Discuss familiar with the Operator Manual before attempting to operate this equipment.
- 2/ Before starting the machine, check that all screws, nuts, bolts and other fasteners are properly secured; make certain that the cutting chamber is empty. Do not operate without guards or screens in place.
- 3/ Do not transport this machine while the engine is running.
- 4/ Before inspecting or servicing any part of the machine, shut off power source, disconnect the spark plug wire from the spark plug and make sure all moving parts have come to a complete stop
- 5/ Never operate this machine indoors.
- 6/ Operate the machine only on a level surface. Keep proper balance and footing at all times. Do not operate machine on a paved or gravel surface.
- 7/ Carbon Monoxide can be extremely dangerous in enclosed areas; do not run the machine in an enclosed area since the exhaust from the engine contains carbon monoxide.
- 8/ Do not allow children to operate this equipment. Do not operate this equipment in the vicinity of bystanders.
- 9/ Obtain and wear safety glasses at all times while operating machine.
- 10/ Do not allow hands or any other part of the body or clothing inside the feeding chamber, discharge chute, or near any moving part.
- 11/ Obtain and wear safety glasses, gloves and hearing protectors at all times while operating the machine.
- 12/ Avoid wearing loose-fitting clothing.
- 13/ Always stand clear of the discharge area when operating this machine. Keep face and body back from the feed opening.
- 14/ When feeding shreddable material into the equipment be extremely careful that pieces of metal, rocks, bottles, cans or other foreign objects are not included.
- 15/ If the cutting mechanism strikes any foreign object, or if the machine should start making any unusual noise or vibration, immediately shut off the engine and allow the machine to stop. Disconnect the spark plug wire from the spark plug and take the following steps:
 - 1/ Inspect for damage
 - 2/ Replace or repair any damaged parts
 - 3/ Check for and tighten any loose parts
- 16/ Do not allow processed material to build up in the feeding opening.
- 17/ If the machine becomes clogged, shut off the engine (or motor), disconnect the spark plug wire and allow machine to come to a complete stop before cleaning debris.
- 18/ Keep the engine clean of debris and other accumulations. Do not tamper with engine governor settings.

< This sticker summarizes in 18 items a number of important safety messages taken from the user manual. Caution : However, this does not imply that there's no need to read the manual.
(Order number : BQ 505 010 200)

WARNING

SHIELD EYES EXPLOSIVE GASES CAN CAUSE BLINDNESS OR INJURY	NO - SPARKS - FLAMES - SMOKING	SULFURIC ACID CAN CAUSE BLINDNESS OR SEVERE BURNS	FLUSH EYES IMMEDIATELY WITH WATER, GET MEDICAL HELP FAST

KEEP OUT OF THE REACH OF CHILDREN. DO NOT TIP. KEEP VENT CAPS TIGHT AND LEVEL.

^ This sticker is located on the battery support tray. It warns the user of the potential hazards of battery acid.
(Order number : BQ 505 010 180)

CAUTION

NEVER EXCEED THE MAXIMUM CAPACITY OF THIS SHREDDER.

MACHINE DAMAGE AND PERSONAL INJURY MAY OCCUR.

READ THE MANUAL FOR OPERATION INSTRUCTIONS AND RECOMMENDATIONS.

^ This sticker is located on the loading hopper at the infeed opening. It reminds the user to operate the unit observing the stated capacity.
(order number: BQ 505 010 190)

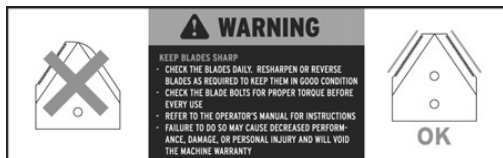

BQ 505 010 250

This sticker is located near the motor starter mechanism. Each time the machine is started, the operator is reminded to inspect and service the blades before turning on the machine. (order number: BQ 505 010 250)



BQ 505 010 240

This sticker is found near the identification sticker. Here, our American customers will find the phone number for technical support in case of problems. (order number: BQ 505 010 240)

7.2 Safety provisions

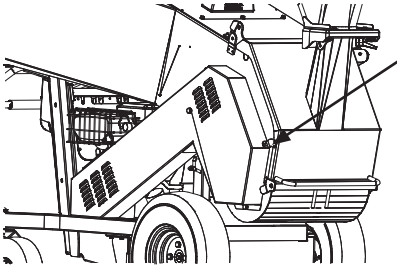

Safety switch:

The safety contact on the maintenance hatch for the blade axle and Axelero™ prevents contact with rotating parts. This maintenance hatch can be opened without the need for tools. When opening, the safety switch turns off the motor and the drive unit. The motor can only be restarted if the maintenance hatch is closed.

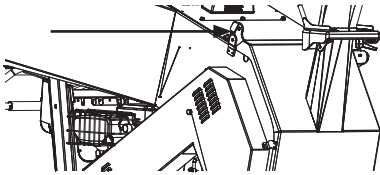

Safety lock:

When opened, the maintenance hatch can be locked into place. This prevents the hatch falling on the operator and causing injury during maintenance.

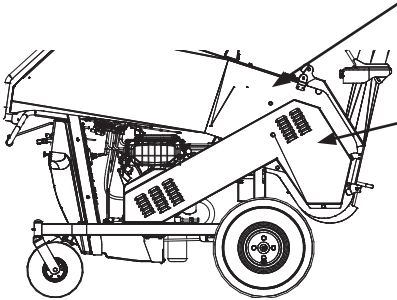

Protective cover V-belt:

This metal cap provides protection against rotating V-belts. The protective cap can only be opened using tools. The motor must always be off when this cap is removed. If the protective cap is dismantled or not fitted correctly, you are strictly prohibited from starting the machine due to the safety risk.

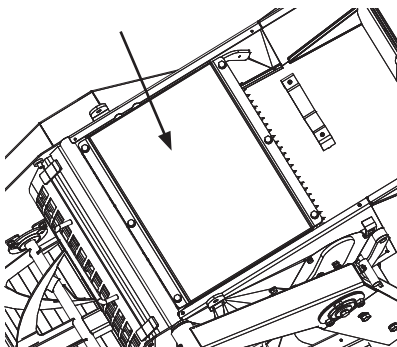

Sound absorption:

The acoustic housing accommodating the knife drum gives excellent noise reduction whilst shredding, therefore, minimising noise nuisance for both the operator and the surroundings.

Rugged construction :

The robust construction not only adds to the long operating life of the machine, but also provides additional user safety whenever there is an unforeseen emergency.

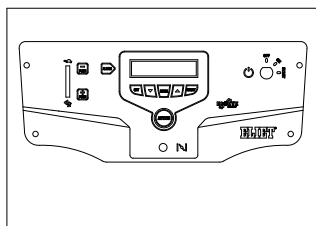
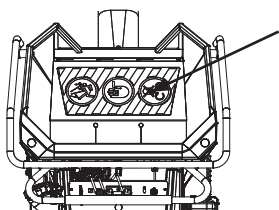
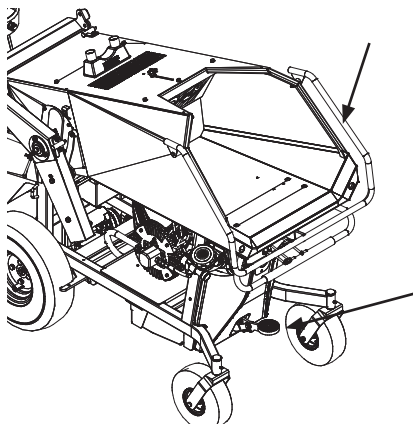

Safety-stop-bracket:

If you press the safety-stop-bracket, the feed roller stops immediately. The feed roller can only be restarted if this bracket is not depressed.

Parking brake:

The parking brake ensures that the machine does not move involuntarily during use. Engage this brake during work or when the machine is to be left.

Safety screen:

The safety screen is specially designed to protect the operator against flying wood chips. Any attempt by the operator to insert his hands beyond this steel sheet is strictly forbidden.

The operator must be aware that lifting this plate means that the protection will be removed and the risks will increase.

Safety wear :

For your safety, we strongly recommend to use the safety kit supplied as standard. It contains your Personal Protective Equipment (PPE). This safety set consists of safety glasses, ear defenders and a pair of riggers gloves.

Dashboard:

The programmed software on the dashboard provides additional warnings about incorrect processes.

7.3 Safety regulations

7.3.1 General safety precautions

- The Owner Manual must stay with the unit during its complete service life. It serves as a reference for the user, and enables the machine to be used and maintained in accordance with the correct instructions. Always refer to this instruction manual if you have any doubts about an action that you are about to perform.
- If the instructions stated in this manual are not clear to you, do not hesitate to contact your Eliet dealer for further explanation. ELIET's helpdesk (+32 (0)56 777088) is also at your disposal during office hours to provide answers for your questions.
- Read the chapter that is meant for the dealer ("8. Dealer's duties" on page 22) and immediately check whether or not the machine has been delivered in accordance with the instructions.
- Carefully observe all safety instructions when using the ELIET machine ! Carefully read all the instructions relating to the use of the machine. All these instructions relate to your personal safety.
- Upon purchasing the machine, allow the dealer or a professional to give you ample instructions about its proper use.
- Ask your ELIET dealer to explain the possible dangers associated with the machine.
- Read and observe all safety messages posted on the machine in the form of stickers or icons.
- Read and observe all safety messages posted on the motor.
- Under no conditions whatsoever may the original design of the machine be modified without the explicit and written consent from ELIET EUROPE NV (Belgium).
- Under no circumstances must a safety item be shunted, disassembled or switched off.
- As shredding involves ongoing considerable physical effort, take regular breaks for food intake, rest and drinking.
- It is unsafe for persons suffering heart problems and/or having balance disturbances to operate the machine.
- Avoid inhaling the exhaust fumes from the machine. Exhaust gases contain toxic particles which could prove fatal. Never start the engine in an enclosed area.

7.3.2 Careful and security-conscious use

- This machine is designed solely for chipping branches, prunings, leaves and all kinds of organic garden debris and shall be used for this purpose only.
- Never attempt to shred frozen branches.
- Think about what you are doing whenever you operate the machine. Do not be tempted to let routine dull your attention. Never act impulsively or in reflex.
- Despite the extensive safety features, do not seek out dangerous situations.
- Take care to preclude any tools falling into the in-feed funnel.
- Do not feed foreign materials. (string, stones, metal, plastic, textile, etc.)
- According to the manufacturer, this model will take branches up to 130 mm diameter. For your

own safety on no account should any attempt be made to introduce stems thicker than the stated capacity.

- The machine is not designed to be subjected to the stated maximum capacity for longer periods. As a guideline: no more than 10 % of the garden waste that is to be fed into the machine may have a diameter in excess of 90 mm.
- Never stand on a step when feeding garden waste into the loading hopper.
- Do not use a fork or a shovel to or a fork to feed the machine with garden waste.
- Do not use your feet to feed garden waste in the loading hopper.
- Never work in conditions where light intensity is less than 500 Lux.
- Always remember to lock the wheels under shredding, so as to prevent the machine from moving.
- For deontological reasons, ELIET accept no responsibility whatsoever for any accidental injury to pets or persons caused by its machines.

7.3.3 Responsibilities of the Operator

- All persons using the machine are assumed to be fully conversant with the safety instructions.
- The operator is fully liable for the use of the machine in regard to himself and to third parties.
- Operators are presumed to possess a certain level of maturity that permits them to make decisions based on common sense.
- Underage persons must not operate the machine. However, this does not apply to youths above the age of 16 years, who are learning to operate the machine under the supervision of an experienced operator.
- A disabled person may only operate the machine when under the supervision of an experienced operator.
- Children and animals must be kept well away from the machine.
- ELIET recommend that the machine should not be lent to others. However, if this is done, only lend it to persons who are conversant with the machine.

Always ensure that the user is aware of the potential hazards and ensure that he reads the manual before he uses the machine.

- This machine must only be operated by persons who are in good physical condition. If you become tired during the work, take a rest in due time. Persons consuming alcohol or drugs must not operate this machine.

7.3.4 Personal Protective Equipment (PPE)

- You must wear suitable clothing to operate this machine. That is, clothing covering the whole body, heavy protective gloves and closed nonslip footwear.
- Do not wear loose fitting clothing (a shawl, for instance, should be avoided by all means). Long hair should be contained using a cap or a headband, or worn in a ponytail.
- For the protection of the most sensitive senses, ELIET recommends ear defenders and safety goggles.
- Shredding may result in dust production. If this dust irritates your lungs, we recommend that you wear a dust mask conform to directive 89/686/EC.

7.3.5 Danger zone

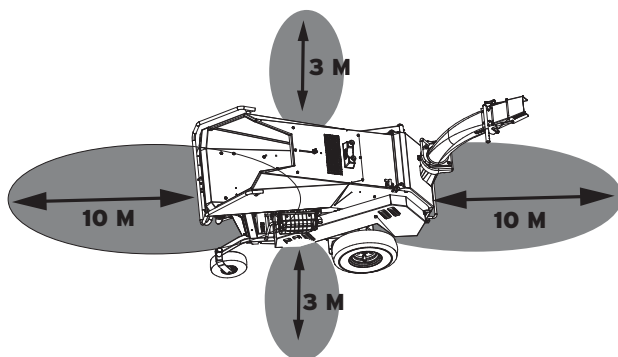

**Graphical representation
of the danger zone**

- During the work, do not allow bystanders to enter the zone of danger that stretches up to 10m around the machine. Do not take any risks and immediately stop the machine as soon as anyone enters the danger area.
- When leaving the machine, the engine must be switched off. Always wait until the blades come to a complete standstill before carrying out any operation. Once the engine is running, focus all your attention on operating the machine.

7.3.6 Periodic maintenance

- Periodic maintenance is essential. For this reason, strictly follow the maintenance schedule in this user manual ("11. Maintenance tasks described in detail" on page 40).
- When replacing parts as a result of wear or failure, always request genuine ELIET service parts from your ELIET dealer. This is important in the interests of your own safety.
- Always make sure the engine is switched off and the battery cables disconnected before performing repairs or maintenance.



For your information

Also, read the engine manual that comes supplied with the machine. This contains the information required for the correct use and maintenance of the engine.

7.3.7 Respect the environment

Use the machine in a manner that respects environmental regulations.

- Avoid unnecessary machine running while not at work.
- Avoid spilling petrol while refuelling.
- Service the engine regularly in order to achieve optimum combustion.
- Avoid the defection of sulphuric acid from the battery.
- When changing oil, the dirty oil must be disposed of in the correct manner, i.e. offered for recycling.

8. Dealer's duties

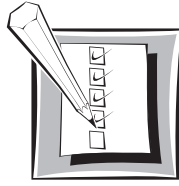

- As an ELIET dealer it is your **duty** to **instruct your customers on the operation of the machine** and to **point out the potential risks** during operation.
You are expected to carefully go over the maintenance points of the machine together with the new owner. Repeat these instructions until the new owner has fully understood everything. The need for pointing out the following issue to the customer is something cannot be over-emphasized :



For your information:

As the manufacturer of the machine, ELIET wishes to re-emphasise that the dealer must expressly point out to the customers the necessity of re-tightening all the blade bolts **within the first 5 operating hours**.

FOR SAFETY REASONS ALL THE BLADE BOLTS MUST BE RE-TIGHTENED AFTER THE FIRST 5 OPERATING HOURS.

- Likewise, make sure to check the belt for correct belt tension after a run-in period of 10 hours.
- Each machine that leaves the factory contains a limited amount of oil and fuel. The dealer must check the levels of the oil and fuel and top them up in accordance with the instructions in this manual (or in the engine manual).
- The Dealer performs a test run on the machine and confirms that everything is functioning properly.
- The rpm will be set at 3,200 rpm.
- The dealer will perform a test run on the machine and confirm that everything is functioning properly (e.g. safety net; emergency stop, etc.).
- He also checks that the bolts securing the blades are fully tight.
- The dealer makes sure the machine is correctly registered on the Eliet website. This, in order to avoid any warranty disputes. For more information, please read the warranty conditions ("16.5 Warranty-conditions" on page 82)

9. Operating instructions



9.1 Preliminary checks



Caution :

Before starting to shred, always run through the checklist below.

Checklist

1. Check the oil level of the machine. (“11.3.1 Checking the oil level in the engine crankcase + refilling” on page 47).
2. Ensure there is enough petrol in the tank. If necessary, fill up the tank with petrol. Be aware that average usage is around 3l/u. (“9.2 Filling up with petrol” on page 24)
3. Check whether the air filter is not too dirty.. (“11.3.4 Cleaning the air filter (Clean air filter)” on page 49)
4. Satisfy yourself that the shredding knives are firmly in place and in good condition.
If they need to be sharpened, this must be done first (“11.4.2 Sharpening the blades” on page 53).
If one detects cracks or fractures in a blade, this blade must be immediately renewed.
 (“11.4.3.2 To replace the shredding blades, proceed as follows: (Replace knives)” on page 59).
For safety’s sake, tighten the blade bolts.
5. Check that the belt tension is correct. If it is not, it must be adjusted (zie “11.4.5 Tightening the V-belt (Tighten belt)” on page 61)
6. Check to see if a maintenance alarm has been activated.
7. Check that all of the safety provisions on the machine are still functioning (“7.2 Safety provisions” on page 16).

Once these items have been checked and approved, you can prepare the area of operation (“9.3 Preparing the work area” on page 25) and move the machine to the work site.

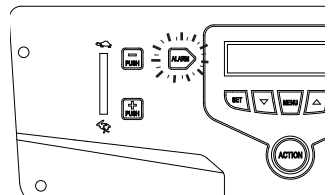

9.2 Filling up with petrol



For your information:

At the back of the petrol tank, there is a gauge-glass. If the level of petrol disappears under the base of the gauge, petrol must be replenished.



For your information:

The petrol tank has a capacity of 18 litres

Top up if the machine runs short of petrol. It's a good idea to only use fresh petrol ("16.1 Technical specifications of the lubricants and fuel" on page 77).

Use lead-free petrol with 85 octane minimal, preferably 98 or 99 octane. Any other fuels are prohibited. (read the engine manual).



Warning:

Under certain conditions, petrol is highly flammable and extremely explosive. Fire and explosion caused by petrol can result in serious burns or damage to property.

- Do not add fuel while engine is running. Always allow a few minutes for the engine to cool off before topping up with fuel.
- Only use fresh petrol.
- Never add oil to fuel.
- Because of the short shelf life of fuel, it is good practice to buy fuel in small quantities.
- Store petrol in an approved container. Keep this container out of the reach of children.
- Store fuel in a well-ventilated area away from open flames, sparks and heat sources.
- Never top up fuel at a location where work is to be performed later. Always keep all persons at least 10 m away from the work area. This is done to prevent any fires from occurring.
- Clean the area around the fuel tank cap (1) and then remove this cap. Never fill a tank to over its capacity. Top up with fuel until the level is approximately 50 mm from the top of the tank. In short, do not fill the tank completely to the tank filler opening.
- Always use a funnel or spout to pour the petrol into the tank. Suitable funnels can be obtained from your ELIET dealer.
- Refit the cap onto the tank as soon as possible.
- Be careful not to spill petrol onto clothing. If petrol does come into contact with your clothing, change this clothing at once.
- It is unsafe and thus expressly forbidden to fill the fuel tank in the

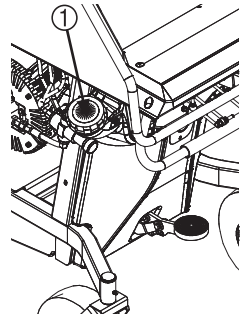

vicinity of smokers or naked flames.

- If fuel comes into contact with the eyes or is taken internally, obtain medical attention immediately.

9.3 Preparing the work area

- Clear the area first where the machine is to be used. In addition, the paths along which the plant trimmings are removed, must be kept clear, thus releasing the operator from the worries of tripping up over them. The operator must also ensure that his safety is not compromised.
- Make sure to locate the machine such that flying chippings expelled from the discharge blow chute output do not cause damage to persons or properties.
- Apply the parking brake once the machine has been placed in the working position.
- On slopes, never operate the machine (no forward, backward or lateral slope).
- Make sure to sort the material beforehand. In this way, the operator is sure that no foreign objects will enter the machine with the material.
- Foreign objects are defined as: any non-organic object or branchy material in excess of the stated capacity (such as metal, stone, plastic, pvc, cords,...). Some of these can cause serious damage to your machine or can be ejected, virtually as projectiles towards the user.
- Always position the machine so that the wind will blow the dust produced away from the engine.

9.4 Starting the Petrol Engine



Caution:

Never start the machine if the engine cooling fins are not clean and free of debris to protect it from overheating.



Ter informatie:

Also, read the engine manual.



Warning:

Never run the engine indoors. Exhaust gases contain toxic substances and may lead to intoxication or suffocation.

Before starting the engine, check whether adequate oil and fuel is present in the engine. If necessary, read the following sections:

“11.3.1 Checking the oil level in the engine crankcase + refilling” on page 47

“9.2 Filling up with petrol” on page 24



Warning:

Before starting up the machine, make sure to wear the ear defenders supplied as standard.

- Ensure the shredding chamber and the Axelero™ are empty. This is to avoid starter mechanism overloading.
- Be sure the shredder hopper is empty (no tools...).

Standard version

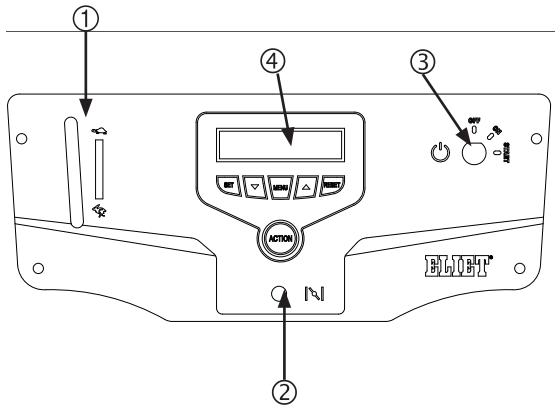

- Move the throttle (1) to the max. (=hare) position.
- Close the valve (choke) (2) by pulling the knob.
- Turn the ignition key (3) to the ON position, and check if the LCD-screen (4) lights up. This way you are able to check the operation of the LCD-screen.
- Turn the key to position 2, the start motor cranks the engine .
- Release the key when the engine starts.
- After 3 to 4 seconds, push the button of the Choke (2) valve slowly back in.
- At ELIET, we recommend to keep maximum engine speed at 3,200 rpm. Check to ensure that the motor is achieving the revolutions indicated when running at full gas. Never try to modify the engine speed yourself.

Switching off the engine :

- Move the throttle control lever (1) to low speed (= tortoise).
- Turn the ignition key (3) to the OFF position and remove from the ignition switch
- Store the key in a safe place away from children and unauthorised persons.

Super Prof with option Eco Eye

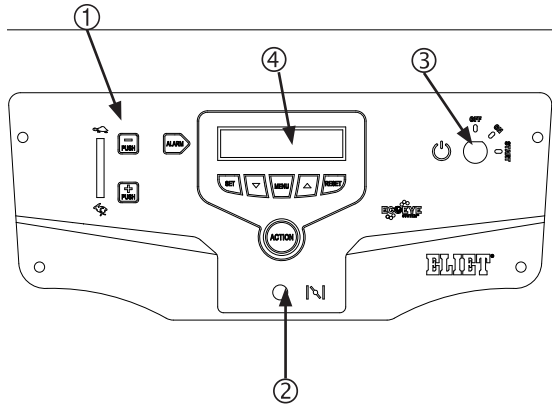

- Close the valve (choke) (2) by pulling the knob
- Turn the ignition key (3) to the ON position, and check if the LCD-screen (4) lights up. This way you are able to check the operation of the LCD-screen.
- Turn the key to position 2, the start motor cranks the engine .
- Release the key when the engine starts.
- After 3 to 4 seconds, push the button of the Choke (2) valve slowly back in.
- Press the + Push button (1) to increase the motor's revolutions.
- At ELIET, we recommend to keep maximum engine speed at 3,200 rpm. Check to ensure that the motor is achieving the revolutions indicated when running at full gas. Never try to modify the engine speed yourself.

Switching off the engine :

- Reduce gas (1) to a lower level (= tortoise) by pressing the - Push button.
- Turn the ignition key (3) to the OFF position and remove from the ignition switch
- Store the key in a safe place away from children and unauthorised persons.

9.5 Moving the machine



Caution:

The machine may only be driven if the blade axle is disengaged so that no chips are being ejected. Driving the machine with the blade coupling engaged could lead to serious damage.

TIP:

It is a good idea to become acquainted with the characteristics of a self-propelled machine and do so in a quiet spacious location without bystanders.

A. If you have a self-propelled machine (ZR type)

- Start the engine ("9.4 Starting the Petrol Engine" on page 25).
- Move the throttle control lever so that the engine runs at low speed .
- Make sure that the blade axle is disengaged so that no chips are ejected. ("9.6.3 During the work" on page 30).
- Moving the machine:

Move the control handle forwards (1) then the machine will move forwards. The more you move the control handle forwards, the faster the speed.

The opposite also works: Turning the control handle backwards will cause the machine to move backwards at a speed proportional to the amount that you move the control handle.

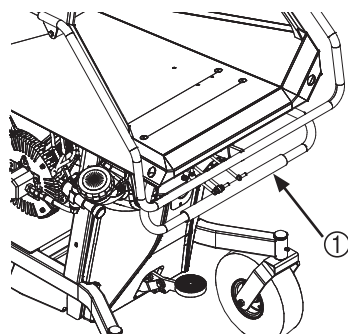

B. If you have the Cross Country version (version with caterpillar tracks)

- Start the engine ("9.4 Starting the Petrol Engine" on page 25).
- Move the throttle control lever so that the engine runs at low speed .
- To move the machine, perform the following steps:
The control handle consists of two separate handles, where the left-hand handle controls the left-hand track, and the right-hand handle controls the right-hand track.
- To move the machine straight ahead (forwards or backwards) : Move both control handles at the same time. Moving both control handles will cause the machine to move forwards, moving them backwards will cause the machine to move backwards.



Caution:

If you do not move both control handles by the same amount, the machine will not move in a straight line.

- To turn to the right: By moving the left-hand control handle (1) through a larger angle than the right-hand control handle (2), the machine turns to the right. The greater the difference between the control handles, the faster the machine will turn.
- To turn to the left: Move right-hand control handle (2) through a larger angle than the left-hand handle (1) will cause the machine to turn to the left.
- To turn the machine on the spot: Move each handle in opposite directions.

WARNING

KEEP YOUR FEET SAFE !

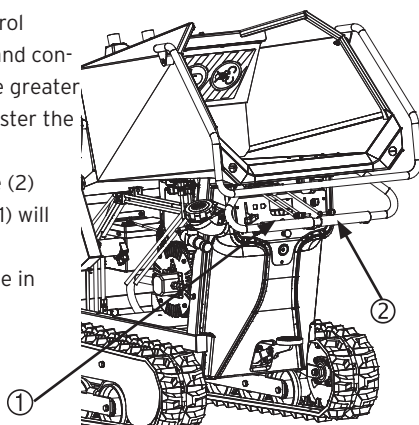

The operator must be on his guard and move the control handles carefully.

**Warning:**

During turning, the machine can change direction sharply.

TIP:

It is a good idea to become acquainted with the characteristics of a self-propelled machine and do so in a quiet spacious location without bystanders.

**Warning:**

You can move the throttle control lever to increase the speed of the machine. This will increase the speed of the engine. (Read the previous tip before operating the machine at working speed.)

9.6 Operating the machine

9.6.1 Before starting work

- Wear proper apparel, protective gloves and safety equipment as instructed in this manual ("7.3 Safety regulations" on page 18).
- A good gardener is well organized and plans his work. This will enable you to have perfect control to avoid accidents.
- The wood should be systematically stacked before commencing the work : thick branches, thin branches, leaves and damp products. Ensure that the material does not contain any foreign objects.
- Never run the machine in an enclosed area. If this is done, there is a danger of being poisoned by the exhaust fumes from the engine.
- Always shred with the engine at full throttle..
- If the machine is set up in a working environment, the parking brake must be applied.

**Warning:**

Before the blade axle is activated, ensure that the blow chute is upright. Point the blow chute and the deflector flaps in the desired direction.

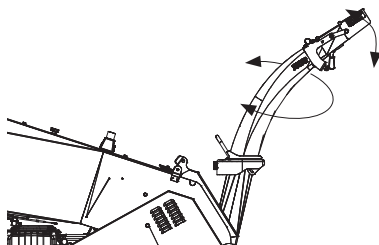

9.6.2 Turning and positioning the blowchute and deflector-flap

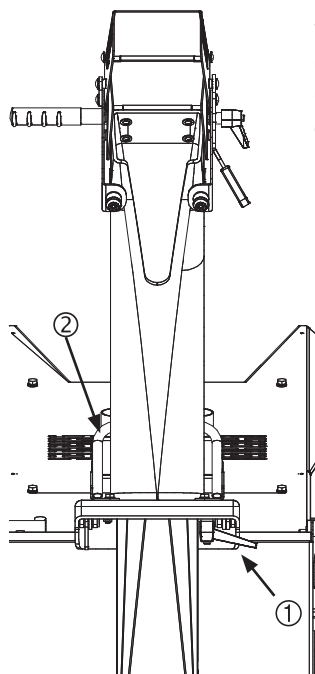

To position the blow chute, the lever (1) is released and the handle (2) on the chute is used to turn it to the appropriate position. Once the blow chute is in the appropriate position, the lever (1) can be secured again.

In order to put the deflector flaps in the desired position, the lever (3) is released, the handle (4) is used to position the deflector flap and the lever (3) is then replaced in order to secure the deflector flap.

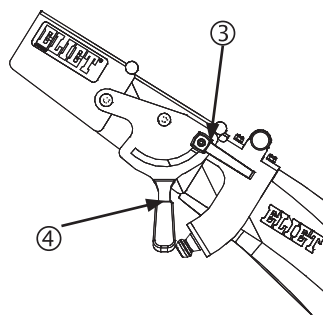

9.6.3 During the work

- Be careful when performing work. While operating the machine, focus your concentration completely on the work
- Start the engine ("9.4 Starting the Petrol Engine" on page 25).
- Allow the machine to run idle for about 5 minutes.

9.6.3.1 Starting the blade system and discharge system

- Always shred at full throttle
- Set the thrust lever to maximum or push the PUSH button on the machine to run at full gas.

In order to shred, the blades and the discharge system must be started. The coupling must be engaged in order to do so. On the dashboard, there is an illuminated button with the word 'Action'. Push this Action button in order to begin shredding.

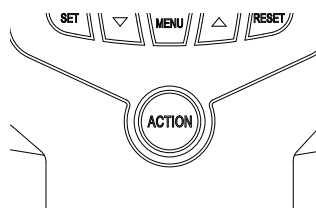

**Warning:**

Once the Action button has been pressed, the blades will rotate and the Axelero™ will be driven. As a result, any remaining chips in the chamber and Axelero™ will be blown out.

**For your information**

When shredding at temperatures around freezing, maximum branch size of branchy material is limited to 70 mm.

**For your information:**

Always shred at full throttle for the engine to produce its full power output.

**Caution:**

If the revolutions are too low, the coupling will not engage when the Action button is pushed. A safety message on the LCD screen will ask you to increase the revolutions. Use the thrust lever.

**Caution:**

If the motor is not sufficiently warmed up, the motor revolutions may drop dramatically as a result of the sudden strain when the coupling is engaged. The Super Prof electronics will prevent the motor cutting out by automatically disengaging the coupling and, after a fraction of a second, engaging it again in order to overcome the inertia of the blade axle and discharge system.

9.6.3.2 Operating the feed roller

In order to simplify operating the feed roller, a clear and well-organised system has been chosen, using buttons on the front of the hopper.

The left button (1) is for inserting the cut waste; the right button (2) is for carrying back the cut waste.

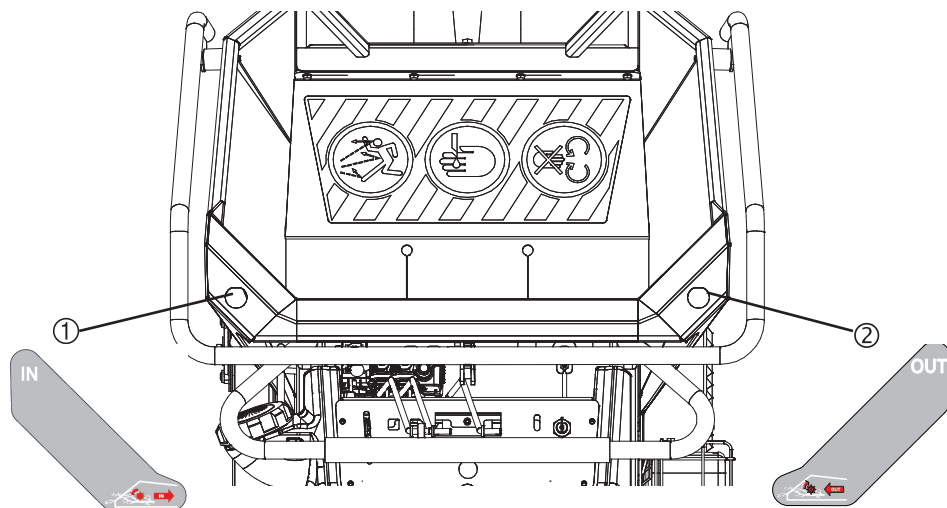

- Push the left button (1) and the feed roller will start moving and pull the cut waste into the feed hopper at a constant speed. The buttons are fitted with integrated LED lights. These light up the button when they are activated. These buttons show the direction of the feed roller.



Warning:

The feed roller can only be switched on if the blades are activated. If this is not the case, a message will be displayed on the LCD screen. Press the Action button to reactivate the blade axle.

- Preferably, the operator's position is next to the black loading hopper to introduce the garden waste. In this way, flying chippings finding their way from below the safety screen that are expelled from the in-feed do not cause personal injury.
- Feed the garden waste into the loading hopper and guide it towards the feed roller. In the case of loose garden waste (leaves, etc.), use a branch to push the material up to the feed roller. (DO NOT USE a shovel or a fork to do this).
- The Axelero™ discharge system creates a suction effect in the hopper in front of the feed roller. Loose cut waste and leaf litter can impede this suction. In order to ensure the Axelero™ suction is effective, the anti-projection flap in the feed hopper can be secured in a raised position.

- Undo the star screw (1) so that the feed hopper can be moved. The anti-projection flap can now be tilted and the leaf litter can move more easily through the feed hopper.

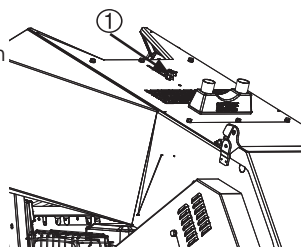

Warning:

If the anti-projection flap is opened, particular attention must be paid to the recoil of cuttings along the feed hopper. Always wear the appropriate protective equipment.

- In the case of branches, it is recommended to feed in the thickest part of the branch first.
- Never use a step for feeding the loading hopper with garden waste.
- Never put your hands further in than the base of the anti-projection cover.
- Never push jammed green waste into the hopper with your foot.



Warning:

Do not lean forwards to push material further into the loading hopper so that your hands NEVER go past the safety screen.

- By reducing the amount of material that you feed into the machine, it will operate more optimally.
- In the case of branches, it is recommended to feed in the thickest part of the branch first.



Caution:

Thick branches that have been sawn at both ends must be fed in from the left hand side of the hopper so that they are guided by the wall. Make sure that branches do not turn diagonally to the supply direction as this can block the machine.

• Automatic overload system (ABM):

To avoid the shredder unit becoming blocked and ensure that the machine can work autonomously, you have chosen an ABM system (anti-block motor). When revolutions reduce as a result of loading, and this falls below 2750 t/min, the feed roller will automatically stop supplying. When the revolutions return to above 2750 t/min, the feed roller will restart.

To stop the feed roller:

- A. push one of both buttons (1 or 2) or
 - B. push the safety-stop-bracket.
- **With speed governing:** If you selected this option (rotary knob underneath the loading hopper), you can control the speed of the feed roller according to the material to be fed in. By adjusting the knob (in the range of 1 to 10), you can obtain maximum efficiency.

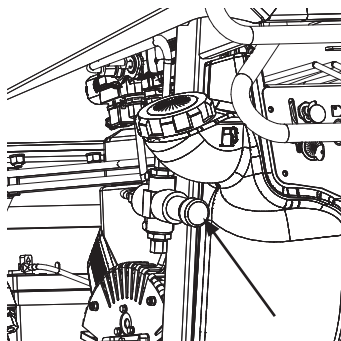

- The rotation direction of the feed roller can be changed by pressing the 'out' button. (2), This is useful if a piece of wood becomes wedged underneath the feed roller.



Caution:

Pressing the OUT button will bring the feed roller to a standstill. If it pressed a second time, the roller will turn in the opposite direction and the green waste will be ejected.

- With moist materials, it is best to use a sieve for damp products. (order number: MA 029 001 011) This sieve can also be combined with other sieves. Read all about the various sieves and various combination options on "13.1 Sieve screening" on page 74



Warning:

In order to avoid personal serious injury or damage to properties, never operate the machine without a sieve screen fitted.

- If the shredding chamber gets clogged up, switch off the machine to remove the blockage. Make sure to wait for the blades to come to a complete standstill, before carrying out any operation on the machine. For safety's sake, disconnect the spark plug wire.
 - Stop the feed roller by pushing the safety-stop-bracket.
 - Press the Action button to switch off the blade axle.
 - Move the throttle control lever to the minimum position.
 - Stop the engine using the ignition key.
 - Open the maintenance hatch in order to access the blade axle and the discharge system(Axelero™) ("11.2.4 Opening the Axelero™ chamber" on page 42)
 - Check the Axelero™ impeller for damage.
 - Open the sieve in order to access the chippings chamber. ("11.2.5 Opening the shredding chamber" on page 43)
 - Check the blades and the blade holders for damage.
 - In the event of damage, carry out repairs before shredding again.
- If you notice a foreign object in the garden waste in the loading hopper, perform the following steps:
 - Push the OUT button to stop the feed roller.
 - Press the OUT button again in order to eject the cut waste.
 - Press the Action button to switch off the blade drive.
 - Stop the engine
 - Now the feed hopper can be reached safely in order to remove the foreign objects among the cut waste.
 - Remove any foreign objects.
- If you notice a strange noise during the work, immediately stop shredding. Stop the engine and investigate the cause of the defect. Before proceeding, perform the necessary repairs.

9.7 Cleaning the machine

It is strongly recommended that you clean the machine after each use. During cleaning, carry out the 'daily maintenance' tasks, see ("11.5.2 Daily maintenance" on page 70)

Failure to do so will :

- Lead to premature wear of the bearings, gaskets and drive belts
- Increase the risk of fire.
- Decrease the cooling efficiency of the engine.
- Inability to detect fractures or cracks.
- Have a detrimental effect on the paint coating and the safety stickers.



Warning:

A machine that is no longer in good working condition may compromise the security of the user.



Caution:

Wear suitable clothing when cleaning.
Gloves are required.



Caution:

When the maintenance hatch is opened in order to access the chipping chamber, it must be locked so that it cannot fall unexpectedly during cleaning.

- Empty the chipping chamber and the Axelero™ each time the machine is used.
- Remove all chippings and green waste that has remained in the feed hopper.
- Remove the build up of chippings and wood residue in the recesses.
- Remove any chippings that are jammed in the guides on the feed roller arm.
- Use a dry cloth, a soft brush, etc. for cleaning. To remove grease and lubricants, use penetrating oil containing molybdenum disulphide. This spray lubricates and also dissolves rust.
- It is useful to have compressed air in the vicinity so that you can use it to clean various components.
- Pay special attention to cleaning the engine. In particular, the cooling fins and air inlet must be thoroughly cleaned in order to guarantee optimal cooling of the engine.
- Make sure that chippings do not remain on the exhaust as this could pose a fire risk or continue to smoulder after the machine has been turned off.
- A steamer may be used for cleaning, Do not spray excessive amounts of water on the bearings, electric components, dashboard and filler caps. Be particularly careful with water on the back

of the dashboard. Pressurised water can penetrate the electrical unit and cause short-circuits.

Moisture can also lead to erosion and, in turn, faults in the electrical system.

Water is known to be the main cause of corrosion and must, therefore, be avoided at all times.

- A washing out of the lubricant is possible ; for this reason, plan a lubrication task after thorough cleaning.
- The engine manufacturer does not recommend water cleaning.

10. Transporting the machine



- Allow the shredder chamber to completely empty. The shredding chamber and the Axelero™ must be empty before transporting the machine. The feed opening should not contain any branches.

- Before loading the Super Prof onto a trailer or into a van, the blow chute must be collapsed so that it leans on the chassis support points. This is the transport position for the blow chute. For the instructions for collapsing the blow chute see "11.2.6 Putting the blow chute in working or transport position" on page 46

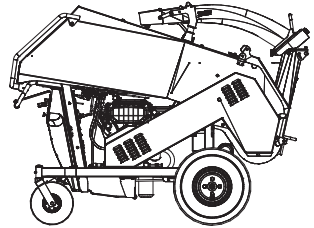

- Use slip resistant ramps to load the machine into a van or a trailer. Make sure that they are securely attached to the vehicle or trailer.
- The maximum allowable lateral slope angle amounts to 10%.
- Under no circumstances must the angle of the up and/or down ramp be greater than 20%.
- Be careful and composed when loading and unloading the shredder so that the machine does not tip over and give rise to an accident.
- When coming down the ramp, move down backwards facing the machine.
- If gravity causes the machine to descend more quickly down the slope than is desired, quickly move the control handle to the other drive direction. This enables you to hydraulically brake the machine.

- Make sure to properly secure the machine to the vehicle during transportation. Use the fixed parts of the vehicle frame to attach ropes. Two eyes are provided at the front in order to secure the unit. Four eyes are provided at the back of the chassis.

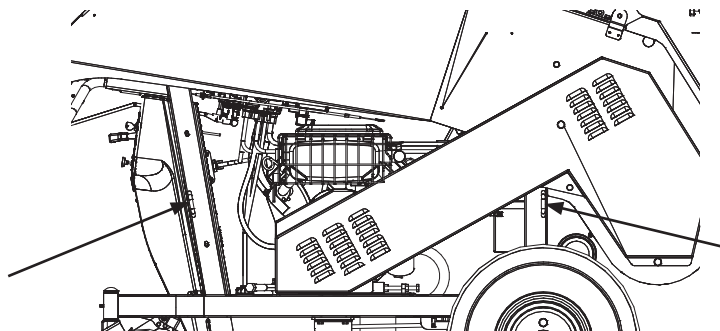

- Always apply the parking brake on the machine.
- Do not forget that the machine has a high centre-of-gravity. Therefore use ropes to secure both sides of the machine to the vehicle. This ensures that the machine is not toppled over when the vehicle goes around a bend.
- Do not overload the vehicle. Read "14. Equipment specifications" on page 75 for the exact weight of the shredder.

**Warning:**

Under no circumstances should the machine be used if the blow chute is in transport mode. The chippings could be blown out in the direction of the operator and cause serious injury.

11. Maintenance tasks described in detail

11.1 General



Ter informatie:

The dealer's personnel are always at your service. The ELIET dealer can always rely on comprehensive support from ELIET NV, so that we can work together to find a solution for any problem that you may have. For a repair or for the maintenance of the engine, you can always contact your ELIET dealer or a maintenance service that is recognized by the engine manufacturer. If you need to contact these services, please provide us with the Model Number and Serial Number of both the machine and the engine, and also describe the problem in detail.



Caution:

Only use genuine ELIET replacement parts. These service parts are manufactured to the same strict quality control requirements and degree of craftsmanship as the original equipment.

For your safety, use only genuine ELIET parts on ELIET machines.

Perform maintenance in a room intended for this purpose. This room must be

- Spacious
- Well lit
- Clean and tidy
- Easily accessible
- Dust-free
- Quiet

These characteristics are important to enable maintenance to be performed in an optimal manner.



Caution:

Improper maintenance may subsequently compromise the safety of the operator.

Prior to doing service operations, first make sure to disconnect the battery cables. (Disconnect the + terminal). Never disconnect the battery for longer than 1 day. If it is disconnected for too long, some components may have to be reprogrammed. When performing maintenance, always wear gloves, and also safety glasses for some operations. These are included with the machine.

TIP:

The maintenance work described can essentially be performed by any person who possesses the requisite technical knowledge. However, ELIET recommend that the machine should be handed in to an ELIET dealer for a major overhaul each year.

Your ELIET dealer is always at your service for maintenance and advice. He stocks genuine ELIET service parts and lubricants. His staff can always obtain advice and service from ELIET, so that they can provide you with an impeccable after-sales service.

11.2 General interventions

**Warning:**

For your own safety: After performing the maintenance, refit ALL guards.

NEVER OPERATE THE MACHINE WITHOUT SAFETY GUARDS !

11.2.1 Removing the belt guard

- Turn the machine off and take the key out of the ignition.
- Remove the following 3 bolts::
 - 1 - (M 10). (SLW17)
 - 2 - (M8). (SLW13)
 - 3 - (M10) (SLW17)
- Remove the guard.

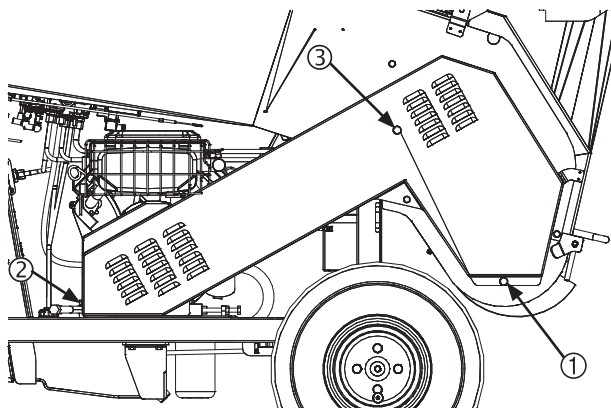

11.2.2 Removing the chain guard

- Turn the machine off and take the key out of the ignition.
- Remove the two bolts (1) (M10 slw 17).
- Remove the guard.

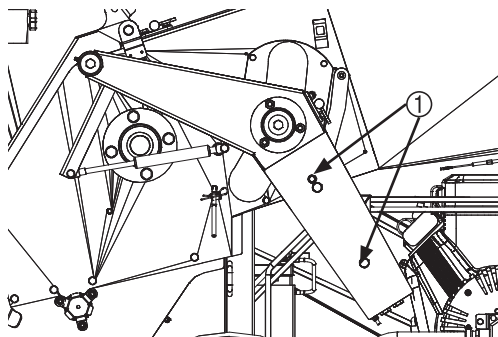

11.2.3 Disconnecting the battery

- Disconnect the negative terminal (1) (black M6 slw 10).
- Disconnect the positive terminal (2) (red M6 slw 10).

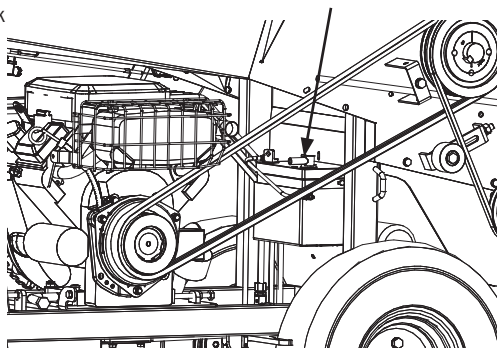
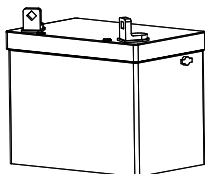

Caution:

First connect the positive terminal (2) (red M6, SW 10). And then the negative terminal (1) (black M6, SW 10). Never disconnect the battery for longer than 1 day.

11.2.4 Opening the Axelero™ chamber



Caution:

Make sure the Axelero™ has come to a standstill before opening the Axelero™ chamber. Turn the motor off and take the key out of the ignition.

**Warning:**

when switching off the petrol engine or disengaging the coupling, it may take up to 7 seconds before the Axelero™ comes to a complete standstill.

**Caution:**

Before opening the Axelero™ chamber, the blow chute should be put into its working position. The Axelero chamber cannot be opened if the blow chute is in transport mode. Read how to put the blow chute into the working position. (Read "11.2.6 Putting the blow chute in working or transport position" on page 46)

- Push the two locking levers (1) towards one another and hold them together with one hand.
- With your other hand, pull the handle (2) and tilt the maintenance hatch upwards

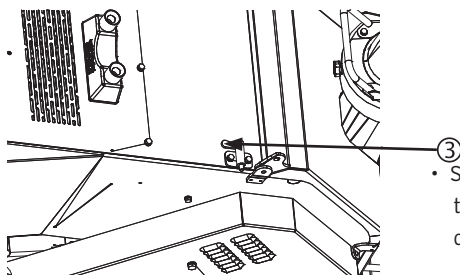
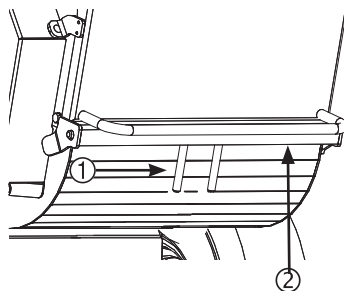

- Secure the maintenance hatch using the lock (3); this will prevent the hatch unexpectedly shutting during maintenance and causing injury.

- In order to shut the maintenance hatch, the lock must be undone while the handle is held. The hatch is then lowered and pushed against the stopper so that the locking pins secure it in place. Pull the handle once again to make sure that the maintenance hatch is closed properly.

11.2.5 Opening the shredding chamber

**Caution:**

Make sure the blades have come to a standstill before opening the shredding chamber. Turn the motor off and take the key out of the ignition.

- Open the maintenance hatch (Read "11.2.4 Opening the Axelero™ chamber" on page 42)
- The sieve that closes off the shredder chamber and shredders that are calibrated to size, comprise two components. An upper sieve and a lower sieve. They are connected together via a hinge.
- The lower sieve is secured to the machine with a pin.
- The upper sieve is clamped into the machine via two tensioning hooks. The tension on the hooks can be eliminated by pulling the black lever (1) towards you.

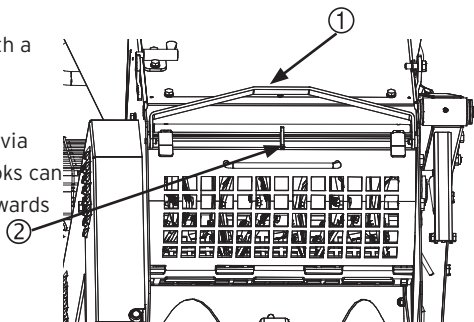

Caution:

When releasing the tension on the hooks, the upper sieve may pop open. The upper sieve often stays in position because the fixed shredders hold it fast. Try to open the sieve using the handle. If the sieve is too tightly fixed, the black lever can be used to provide leverage. Place the specially formed pressure foot (2) on the axle against the handle. Pushing downwards on the black lever now exerts additional pressure on the upper sieve in order to push it open.



Caution:

Do not hold onto the sieve using the handle otherwise your fingers could become jammed between the handle and the lock.

- The upper sieve can be removed from the machine by unhooking it from the hinge with the lower sieve.

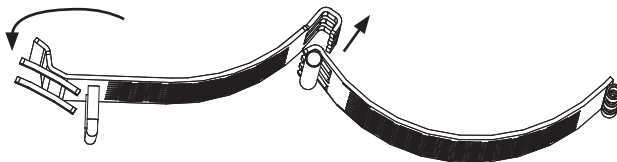

Warning:

The blades are extremely sharp. Avoid contact with the blades and always wear the necessary, appropriate protective gear, such as gloves.

In order to dismantle the lower sieve, the beta pin (1) must be released and the pin (2) removed from the sieve.

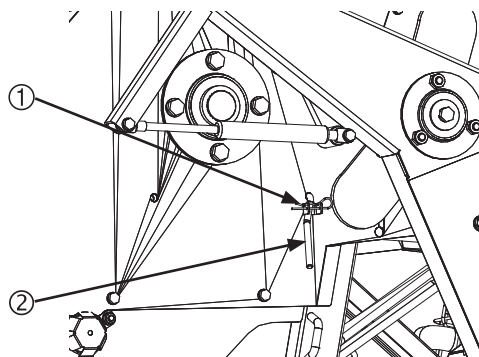

Caution:

Make sure that the sieve is closed correctly and cannot fall open voluntarily. A sieve that opens during work can cause considerable damage to the machine and could pose a hazard for the operator and any bystanders.

- When closing, you must ensure that the hooks are placed in the correct position. When moving the black lever, there must be sufficient tension on the hooks. If this is not the case, the hooks should be adjusted.
- Use an SLW 13 wrench to undo the locking nut on the threaded end of both hooks.
- Undo the nuts by a few turns (clockwise) and then both hooks must be turned one rotation in order to test the tension on the lever. If this is insufficient, the hooks must be progressively turned until the tension is adequate. Then tighten the locking nuts securely.
- If it seems, when changing the sieve, that there is too much tension on the lever, the hooks must also be adjusted (undo, anti-clockwise)

11.2.6 Putting the blow chute in working or transport position



Caution:

The machine can only be used if the blow chute is in the working position. The machine must never be switched on if the blow chute is still in the transport position.

- Before putting the blow chute into the transport position, you must ensure that the deflector flaps are folded-out as far as possible. (see “9.6.2 Turning and positioning the blowchute and deflector-flap” on page 30). Lock them into this position.

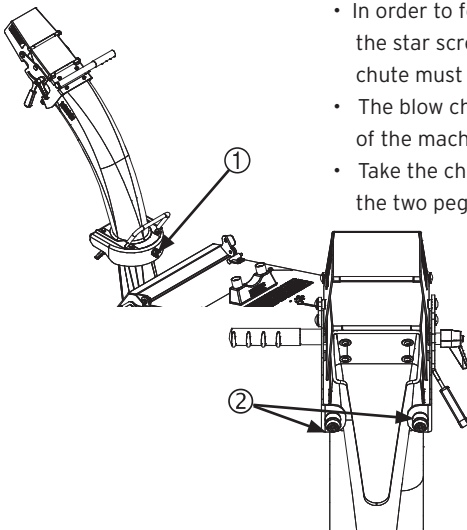
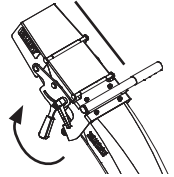

- In order to fold back the blow chute, the star screw (1) on the front of the chute must first be undone.
- The blow chute is then turned so that it is facing the front of the machine.
- Take the chute by the handle and fold it forwards so that the two pegs (2) click into the holder (3).

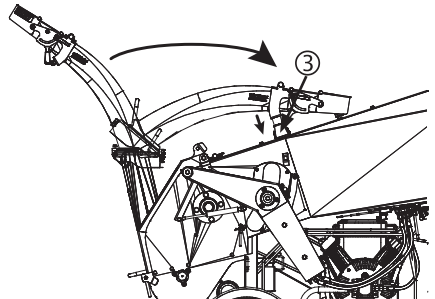

- Tighten the star screw (1) so that it does not get lost.

11.3 Engine maintenance



Warning:

When running, engines emit carbon dioxide: an odourless and colourless poisonous gas. Inhaling carbon dioxide can cause nausea, fainting or death.

Start the engine outside.

NEVER run the petrol engine powered machine in an enclosed area, even with the windows and doors open.

11.3.1 Checking the oil level in the engine crankcase + refilling

Inadequate oil in the engine will cause irrevocable damage to the engine. Therefore, regularly check the oil level as follows.

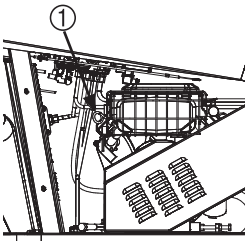

- Park the machine on a level surface so that the engine is perfectly horizontal.
- Switch off the engine and remove the ignition key from the ignition switch.
- Take a clean cloth.
- Remove the dipstick (1) and use a cloth to wipe it clean (the oil level shown on the dipstick is not always correct the first time that the dipstick is removed). Therefore reinsert the dipstick and then remove it again. The oil level must reach the "F"(Full) mark on the dipstick.
- If not, top off (Note : do not overfill).

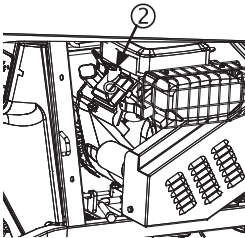

- First clean the area around the filler cap (2) before topping up the oil..
- Remove the filler cap and remove the dipstick so that the crankcase is ventilated.



Caution:

Topping off the oil level is a meticulous job : do not overfill the reservoir to extend engine life and maximize engine performance.

- Gently replenish the oil reservoir. Regularly check the oil level on the dipstick (to see when the desired level has been reached).
- Only use the recommended oil (read "13.1 Sieve screening" on page 74).
- Once the crankcase is replenished with the correct oil, place the check plug back in position and securely retighten the oil filler cap.

- Immediately clean away any spilled oil.



Caution:

Make sure that no dirt enters the crankcase via the filler cap.

11.3.2 Engine oil change (Engine Oil)



Warning:

Filling the engine with oil is performed in TWO steps:
Read all of the text carefully!

- Park the machine on a level surface so that the engine is perfectly horizontal.
- Allow the engine to run until it reaches normal operating temperature, then switch off the engine (and remove the ignition key).
- Hold a receptacle (capacity 2 l) underneath the oil drain plug (1).
- Open the fill cap (2).
- Open the sump plug (1) and allow the contents to drain into the receptacle.
- Once all of the oil has been removed from the crankcase, replace the drainage bung.
- Partially fill the engine with fresh oil and refit the filler cap. (Consult the engine manual for the exact number).
- Start the engine and allow it to idle for 20 seconds.
- Stop the engine and wait for 30 seconds.
- Then gradually fill the engine with the rest of the oil until it reaches the "F"(Full) mark on the dipstick.
- Immediately clean away any spilt oil.

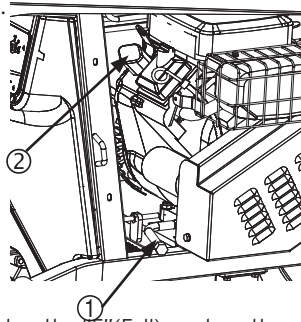

Warning:

Insufficient oil in the engine can cause irrevocable serious damage to the engine.

11.3.3 Changing the oil filter (Oil filter)

- This is performed during an oil change (read "11.3.2 Engine oil change (Engine Oil)" on page 48)
- Verwijder de riemafscherming voor een eenvoudigere toegang tot de filter (read "11.2.1 Removing the belt guard" on page 41).

- Hold a receptacle underneath the filter.
- Remove the used filter (1) after allowing the oil to drain (if stubborn, use an oil filter wrench).
- Apply a film of new oil to the sealing gasket of the new filter.
- Put new oil in the oil filter cartridge.
- Screw the new filter onto the mounting base until the gasket just touches.
- Now tension it fully by turning it a further half to three-quarters of a turn.
- Clean away any spilt oil.
- Add the recommended amount of oil in the manner described above.

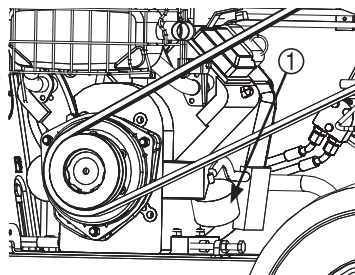

11.3.4 Cleaning the air filter (Clean air filter)

- Undo the hold-down clamps (1) retaining the cover of the air filter and remove the cover.



Caution:

If the engine has just been stopped, the exhaust will still be hot.

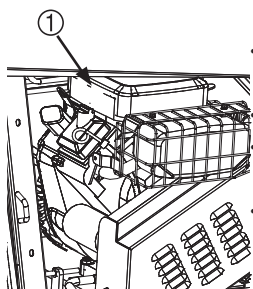

- Before removing the the filter, use compressed air to remove dirt and dust building inside the filter housing. Gently remove the pre-cleaner from the cartridge. Remove the nut and the sheet of the filter medium first and then remove the cartridge. (Prevent the carburettor from becoming dirty).
- Clean the pre-cleaner using liquid detergent and water. Dry the filter in a clean cloth, soak it in oil then dry the filter again in an absorbent cloth in order to remove the excess oil.
- Clean the cartridge by tapping it gently against a flat surface.
- Refit the cartridge (with the UP mark showing upwards) and screw down.
- Refit the pre-cleaner to the cartridge.
- Refit the cover and secure the cover using the hold-down clamps.

11.3.5 Changing the air filter

These actions are almost identical to cleaning the air cleaner (read "11.3.4 Cleaning the air filter (Clean air filter)" on page 49). The only difference here is that the cartridge is replaced. New air cleaners of the correct type are available from your ELIET Dealer or from an authorized Briggs & Stratton service centre.

11.3.6 Changing the engine fuel filter (Oil filter)

- Switch off the engine and remove the ignition key from the ignition switch.



Warning:

Let de motor cool down completely, in order to avoid fire.



- Release the tensioning belts (2) using a flat-head screwdriver.
- Pull the filter out from between the fuel lines.
- Insert the new filter (whilst taking note of the direction of the arrow marked on the filter). New filters are available from your local Eliet dealer or from a B&S service center.
- Move the tensioning belts on the section of fuel hose that sits on the filter.
- Retighten the straps.
- Clean up any spilt fuel.
- Start the engine and inspect for signs of leakage.

11.3.7 Changing the hydraulic oil

- Place a collecting tray (15l capacity) under the oil outlet. (1).
- Open the filler cap (2).
- Open the drainage bung (1) (socket 6mm) and let the oil run into the tray.
- Replace the drainage bung.
- Fill the motor with 12l of new oil (read "16.1 Technical specifications of the lubricants and fuel" on page 77) and shut the filler cap.
- Clean up any spilt fuel.

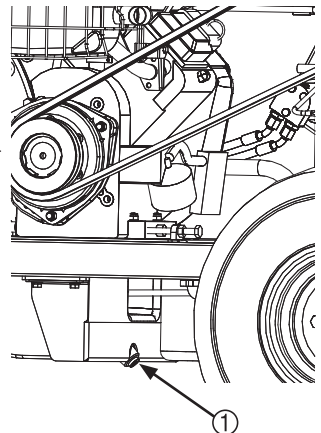
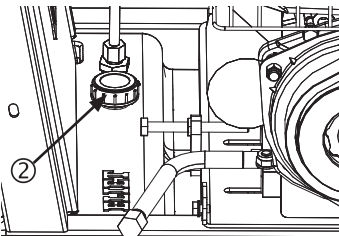

11.3.8 Changing the hydraulic oil filter (Hydraul. filter)

- Organise the replacement of the filter cartridge when the hydraulic oil is being changed.
- Provide a collecting tray with a 15l capacity and place it under the filter.

- Remove the used filter (1) after allowing the oil to drain (if stubborn, use an oil filter wrench).
- Apply a film of new oil to the sealing gasket of the new filter.
- Screw the new filter onto the mounting base until the gasket just touches.
- Now tension it fully by turning it a further half to three-quarters of a turn.
- Fill the hydraulic tank via the filler opening (2) up to 2 cm under the neck of the filler cap.

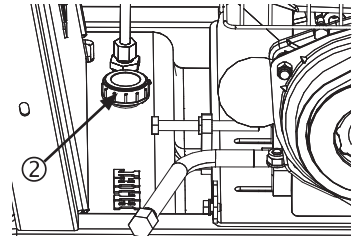
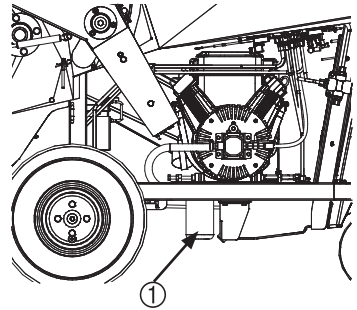
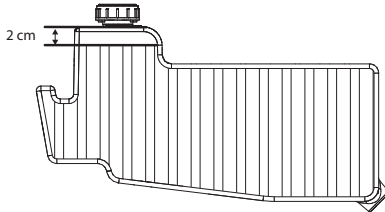

11.4 Machine maintenance

11.4.1 Checking the blades

Sharp shred knives will give the machine optimum performance and provide maximum operating speed. Enhance your own work comfort by taking some time to check the blades, and if necessary, sharpen them.

SHARP BLADES = OPTIMUM PERFORMANCE

Pay particular attention to the following:

Shredding garden waste with the ELIET shredding system takes place in two steps. We first have the contact of the blades with the garden waste when chopping takes place where the cutting block can be found. The wood and green material is roughly cut into pieces until large irregular chippings are obtained during this **primary shredding (1)**. These large chippings end up in the shredding chamber where they are finely chopped to produce small chippings. This **secondary shredding (2)** will continue until the chippings are considered to be small enough to pass through the openings in the sieve screen or as soon as they're small enough to be ejected.

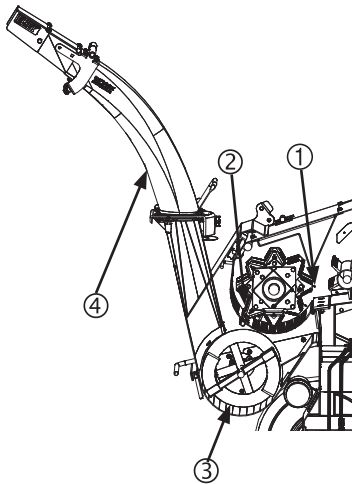

The chippings fall through the calibration sieve in the Axelero™ chamber (3), where they are ejected as a result of the 'axeleration' effect via the blow chute (4).

Each of these shredding actions set certain criteria that the blades must meet for an optimal shredding efficiency:

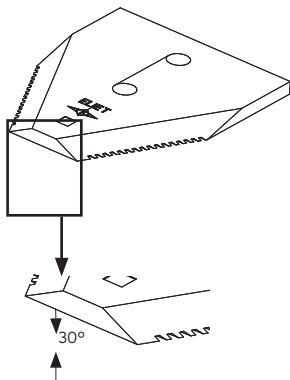

The top of the blade, in particular, is important with regard to the primary shredding. Since the blades act as splitting blades, the cutting angle is essential because this forms the key that will cleave through the wood. The cutting angle of the cutting edge of the blade is by preference 30°. The sharper the blade edge, the less resistance when splitting and the smaller the cutting impact on the structure. This will produce significantly fewer vibrations and noise. This will also benefit the load on the blade shaft and the bearings. You can ensure that the cutting angle is the best possible at all times by regularly grinding. (read "11.4.2 Sharpening the blades" on page 53)

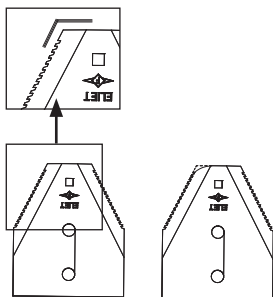

On the other hand, the form of the top of the blade is of essential importance for the performance and the speed of this primary shredding. The angle of the top of the blade will determine the angle at which the wood is pulled inside the shredding chamber. If this angle is rounded off due to wear, turn the blades around or replace them. (read "11.4.3 Reversing and renewing the shredding knives (Turn Knives)" on page 55)

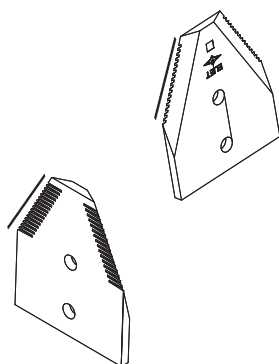

The issue is to have the chippings leave the shredding chamber as quickly as possible with regard to the secondary shredding. The chippings, therefore, must be quickly reduced until they are small enough to pass through the openings of the sieve screen. Every contact with the cutting area of a blade must make the individual chipping smaller. The sharper the full active cutting edge of the blade, the more efficient the shredding will be. Regular grinding of the cutting edge is essential.

The teeth on the cutting edge ensures that the cutting power of the blades increases and the cutting edge remains sharp for a longer period of time. It is very important to never grind away the teeth when performing maintenance on the blades. (read "11.4.2 Sharpening the blades" on page 53)

The position of the blades on the blade shaft has been selected very specifically to obtain an alternative chopping configuration with regard to the primary shredding and the correct circulation of the chippings in the shredding chamber with regard to the secondary shredding. Always observe the original set-up of the blades when reversing or replacing them. (read "11.4.3.1 To reverse a shredding blade, proceed as follows" on page 56)

11.4.2 Sharpening the blades

Correct and timely sharpening of the shredding blades will extend their operating life (we recommend at least every 10 working hours).

Preparatory warnings

- Always wear safety glasses and hearing protection when grinding blades. Gloves are also mandatory for performing the maintenance work.
- NEVER turn the blade shaft by grabbing the blades. Use the AXELERO to turn the rotor.
- The blade has two cutting edges (reversible blade). This means that you must take into account when sharpening that there is another razor-sharp blade side.
- Remove all wood dust and chipping residue from the shredding chamber, around the blade

shaft and from the Axelero™ chamber. This to ensure fire cannot occur once glowing sharpening fillings is deposited..

- Remove the key from the ignition for your own safety.
- Open the shredding chamber (read "11.2.5 Opening the shredding chamber" on page 43).



For your information

The blades can be sharpened without having to disassemble them. Use a small angle grinder with a grinding disc suitable for steel.

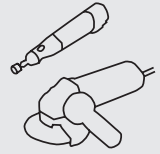

A blade has two sides.

- The front of the blade has the two chamfered cutting edges. **(F)**
- The rear clearly shows the teeth profile of the cutting area. **(B)**

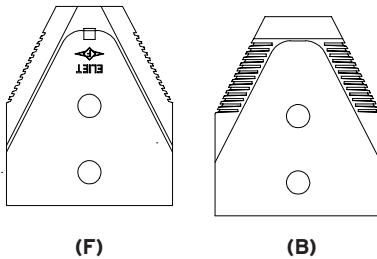

As described in "11.4.1 Checking the blades" on page 52, A sharp cutting edge and a correct cutting angle are essential for efficient shredding. These two properties of the blades are retained in position by correctly sharpening the blades.

- If blades become blunt, the sharp cutting edge will become worn and will be upset to form a wider rib. **(1)**
- By grinding a little metal from the cutting edge, you can again obtain a sharp cutting edge from this wide rib. **(2)**
- This grinding is performed by moving the grinding disc along the angled cutting edge.
- **Note:** By regularly grinding, you will only have to only grind away a small adjustment of the metal to again obtain a sharp cutting edge. This ensures that the times that you grind will be very short and will ensure that you always work with the best possible cutting edge. (ELIET recommends grinding every 10 working hours.)
- Avoid grinding at the same location for a longer period of time.

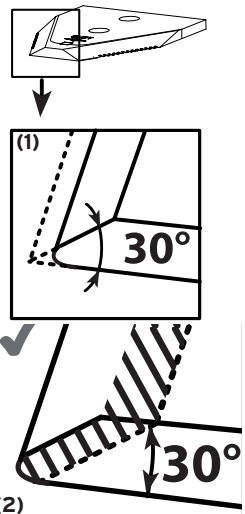

Prevent local discoloration of blades; this denotes heating that causes the material structure to change locally and the hardness to decrease.

- It is extremely important that the existing cutting angle be respected when grinding. **(3: badly grinded blade)**

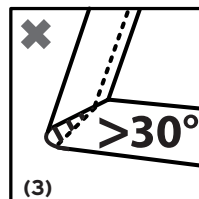

- If the cutting angle is not maintained, blades will be stopped in the wood due to a blunt angle **(4)** of an interrupted cutting angle **(5)** and a lot of power will be lost. A cutting angle that is too sharp **(6,7)** will weaken the cutting edge and, therefore, the blade life of the blades will be significantly shortened **(see pictures 4,5,6 and 7)**.

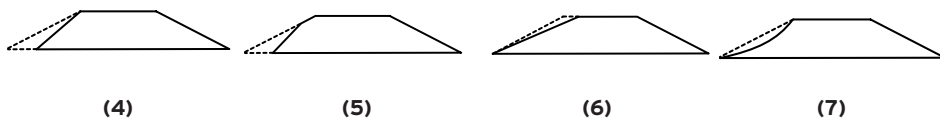

- Never grind the rear side of a blade. In the case of RESIST/10™ blades, the profile is on the rear side. If you grind away the teeth, the blade will lose a great deal of its cutting force.
- The top of the blade is subjected to the heaviest loads during shredding. Sharpen this as little as possible so that it is not weakened.
- Every time you grind you remove some material and the blade will become smaller on the active cutting side. You can continue to grind until you have reached halfway through the width of the top of the blade (see picture). Should you continue to grind, you would compromise the blade life of the cutting side that has not yet been used. Turn the blades when this happens (read "11.4.3 Reversing and renewing the shredding knives (Turn Knives)" on page 55).
- If the top of the blade is rounded-off, (see picture) the shredding efficiency will be reduced. In this event, further grinding of the blade serves no purpose. This is the time to reverse or renew the blades. (read "11.4.3 Reversing and renewing the shredding knives (Turn Knives)" on page 55).
- Carefully close the chipping chamber and the Axelero™ after grinding.

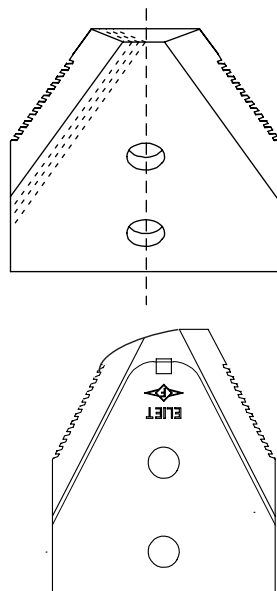

11.4.3 Reversing and renewing the shredding knives (Turn Knives)

If blades are sharpened at regular intervals, a blade life in excess of 100 hours for each blade edge can be realised. When one blade edge has reached the end of its service life, simply reverse the blade, thereby enabling the machine to operate for another 100 hours. If both blade edges are worn, replace the blade as a set.

11.4.3.1 To reverse a shredding blade, proceed as follows



Warning:

Wear protective gloves as the blades are razor sharp !

Remove the machine key from the ignition.

- Open the shredding chamber:
 - tools are not required to open the calibration sieve. This is fitted with a quick and easy opening/closing mechanism
 - read "11.2.5 Opening the shredding chamber" on page 43 and follow the steps.

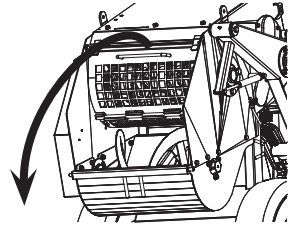

Warning:

The blades are directly exposed as soon as the shredding chamber is open. Be sure that the machine has completely stopped and remove the key from the ignition.



For your information:

The blades are extremely sharp. Avoid contact with the blades en allways wear protective clothings.

- Each blade is secured with two M8 bolts. (M10 bolts on the Super Prof Max.)
Avoid injury to hands and always use two ring spanners with long handles to unscrew the bolts.
- Immediately replace any damaged bolts
- Do not pull away the blades using your hands but use a self-grip wrench.
- It is useful to put a wedge (screwdriver) in-between the blade disks to ensure it is easy to release them.

There are a few rules that must be respected for reversing or replacing the blades. The blade shaft has been divided into two groups for the logics of these rules:

Blade group 1: The two farthest blade disks belong to this group. (**G1**)

Blade group 2: This group contains 4 blade disks that are enclosed in-between the two farthest blade disks. (**G2**)

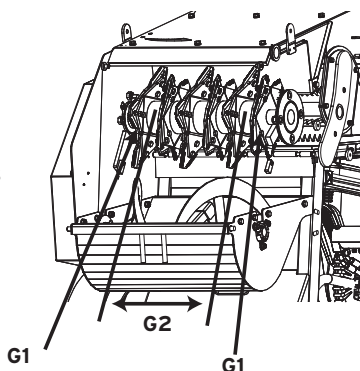

For your information

Each blade has two sharp sides (image)

Front side (F) : The side with the chamfered cutting edge.

Back side (B) : The side with the clearly visible tooth profile.

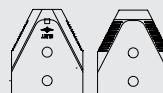

(F)

(B)

A Reversing the blades of group 1

Rule: Ensure that the blades from blade group 1 are always facing with their back side (B) towards the side walls of the shredding chamber.

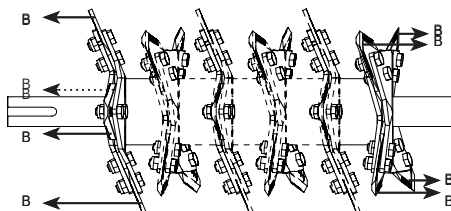

Perform the following steps to consistently apply this rule:

- Remove a blade from the left-hand side, rotate it through 180° and fit it in the same position, but to the right-hand disk. Rotate (180°) the blade previously removed from the right-hand blade disk, and fit it in the empty space in the left-hand blade disk. Repeat this procedure for each blade (8 x) of group 1.
- Always clean the blades and blade holders before reinstalling them.

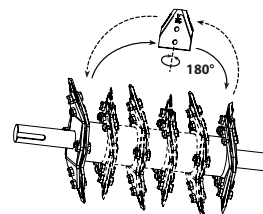

B Reversing the blades of group 2

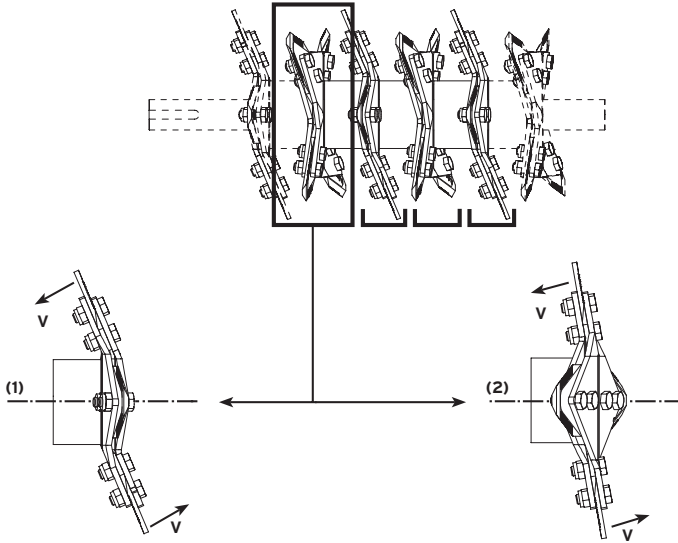

Regel : Rule: Every blade disk has four blade positions. The blades are positioned at an angle for two positions **(1)** and the blades are approximately straight for two positions **(2)**. The front side (F) of the blade must always be directed towards the axis line of the rotor for the slanted blades. One blade will point **(F)** the front side to the right and the other will point **(F)** the front side to the left for the straight blades.

Perform the following steps to consistently apply this rule:

- Disassemble two blades that are diametrically opposite each other. Rotate them through 180° and change them over. Do the same with the two remaining blades. Repeat this operation for the three remaining blade disks of group 2.
- Always clean the blades and blade holders before re-installing them.

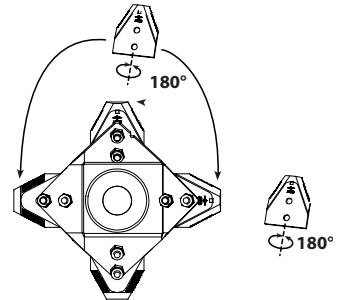

Caution:

When fitting the blades, always position the nuts on the left-hand side of the blade plate. By applying this installation method, the nuts will be automatically tightened during shredding by the turning direction of the blade shaft. As a reminder: "Always position the nuts on the belt pulley side."

11.4.3.2 To replace the shredding blades, proceed as follows: (Replace knives)

- The new set of blades, type RESIST/8 / RESIST/10 for Super Prof MAX can be purchased from your ELIET dealer using the following order number: BU 401 300 202 / Super Prof Max: BU 401 301 000.
- Disassemble all bolts (M8) (Super Prof MAX M10) that secure the blades. Always use two ring spanners with long handles to unscrew these bolt attachments.
- Do not pull away the blades using your hands but use a self-grip wrench.
- It is useful to put a wedge (screwdriver) in-between the blade disks to ensure it is easy to release them.
- First remove any dirt between the blade plates before you insert a new blade. To do so, use a stripping blade.
- Now carry out the steps that must be followed in order to turn the blades (Read "11.4.3.1 To reverse a shredding blade, proceed as follows" on page 56)

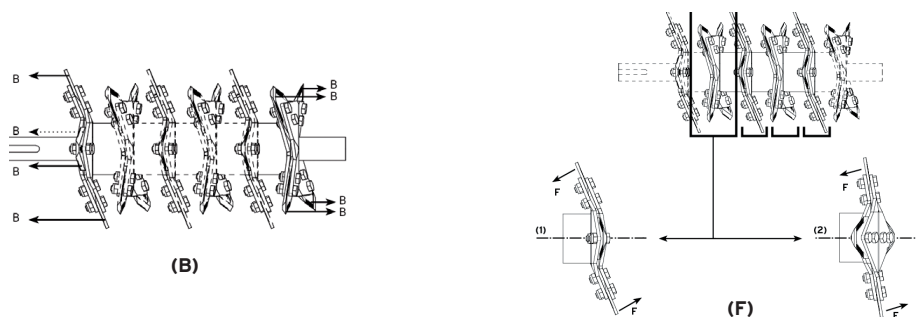

Group 1: Check that the rear of each blade faces towards the wall **(B)** of the shredding chamber.

Group 2: Each blade that is mounted on a fluted part of a blade disk must face the axis line of the blade shaft with its front side **(F)**.

- On replacing shredding blades, always fit new bolts and nuts.
- When refitting the shredding blades check that all bolts are tight (read "16.2 List of torques" on page 78).
- When refitting the bolts in the discs, always make sure the nut is located on the left side of the disc. As a reminder: "All nuts in the blade shaft must always be positioned along the side of the pulley".
- After reversing or replacing the blades, always check the torque of the blade bolts after the first 5 working hours and adjust, if required.



Caution:

Check the torque of the blade bolts after the first 5 working hours !



Caution:

- Incorrectly or poorly installed blades may lead to the machine breaking down or being damaged. This will also put operators and bystanders in danger.
- Not retightening the blades after the first 5 working hours after reversing or changing the blades may lead to the machine breaking down or being damaged.
- The damage and consequential damage that may arise from poor maintenance of the blades will invalidate the warranty.

11.4.4 Checking the drive belt for correct tension (Chk Belt Tens.)

There are two belts on the Super Prof, both are hidden behind the belt protection guards for safety. In order to check the tension on the belts, you must do the following:

Belt 1: Engine - Mesas

Belt 2: Blade axle - Axelero™

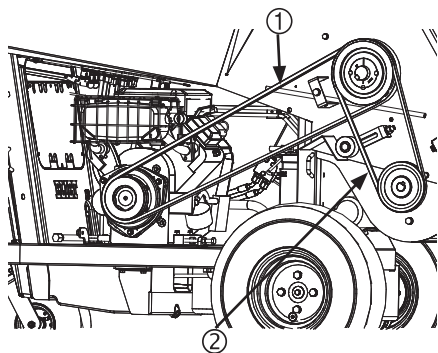

Belt 1: Engine - Blade axle

- Remove the belt guard (read "11.2.1 Removing the belt guard" on page 41).
- Place an 6 kg load on the V-belt midway between the two pulleys.
- If this produces a 1 cm deflection, then the belt tension is correct.

Belt 2: Mesas - Axelero™

- Place an 4 kg load on the V-belt midway between the two pulleys.
- If this produces a 1 cm deflection, then the belt tension is correct.

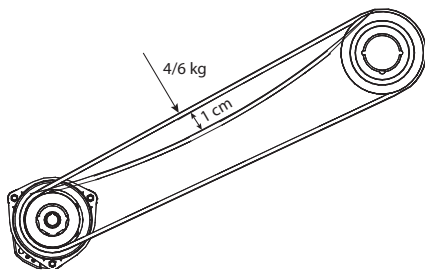

11.4.5 Tightening the V-belt (Tighten belt)

Riem 1: Engine - Blade axle

- Loosen the guide bolts (3 & 4) and unscrew them 2 cm.
- Position a metal plate between the base of the engine and the bolt (4) and retighten this bolt.
- Partially unscrew the 4 bolts retaining the engine (5, 6, 7, 8) (M10 slw. 17).

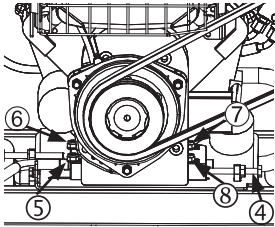
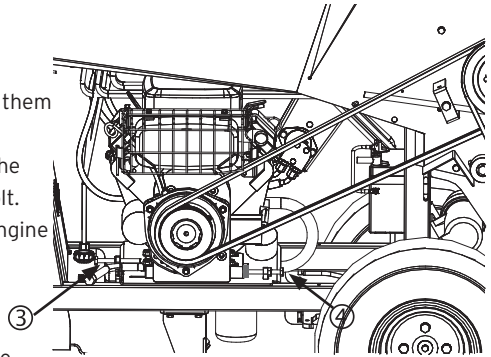

- Push the engine forwards via the tensioning bolt (4). Ensure correct belt tension.

- Align the belt pulleys. To do so, use a straight slat (length : +/- 1200 mm) and hold it against both belt pulleys. When the alignment is correct, the slat will touch the belt pulleys at 4 locations.

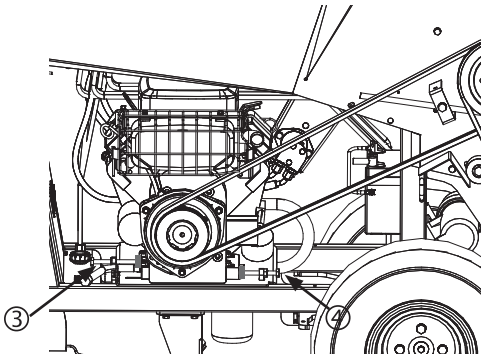
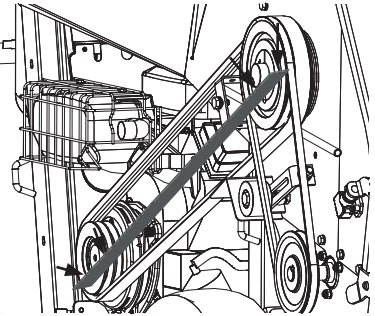

- Position a metal plate between the base of the engine and the guide bolt (3).
- Then screw the guide bolt (3) further in to adjust the belt alignment.
- When the belt is perfectly aligned, retighten the 4 tensioning nuts.

- When the engine is tensioned, remove the metal plates between the engine block and the guide bolts (3 & 4) and screw the guide bolts until they just touch the engine block. Lock the guide bolts using the lock nuts.

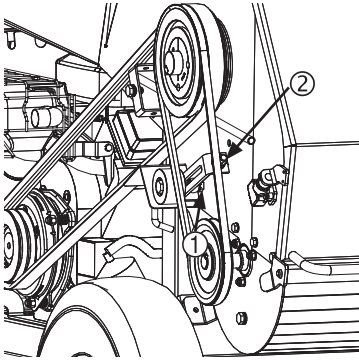
Belt 2: Blade axle - Axelero™

- Loosen the nut on the back of the tension roller (1) but do not undo completely.
- Turn the tensioning bolt (2) in order to position the belt tension roller so that the tension on the belt is correct.
- If the tension was set correctly, the nut on the rear of the tension roller (1) must be re-tensioned.

11.4.6 Changing the belts (Replace Belts)

To replace the belt that drives the blade axle (1), the small belt (2) that drives the Axelero™ must first be undone.

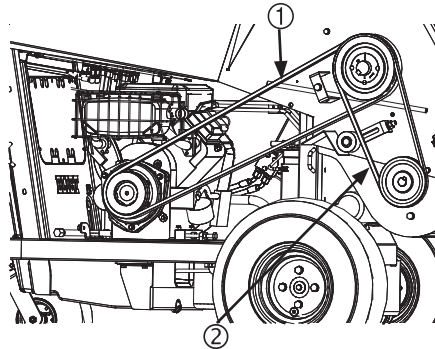
**Belt 2: Blade axle - Axelero™**

- Remove the belt guard (read "11.2.1 Removing the belt guard" on page 41).
- Loosen the nut on the back of the tension roller (1) but do not undo completely.
- Undo the tensioning bolt (2) so that the tension roller for the belt can be moved aside.
- Remove the belt.
- Order number for a new belt: BA 521 212 070
- If you are only replacing this belt, read "11.4.5 Tightening the V-belt (Tighten belt)" on page 61 to re-tighten the belt.

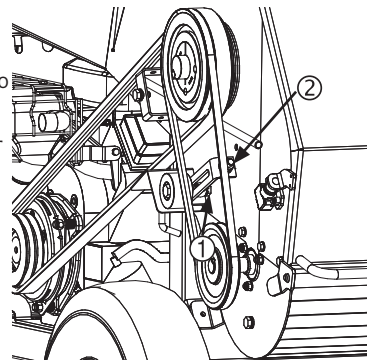

Belt 1: Engine - blade axle

- Remove the small belt (blade axle-Axelero™)
- Unfasten the guide bolts (3 & 4).
- Undo the 4 bolts on the motor (5, 6, 7, 8) (M10 slw. 17).
- Move the motor block in order to release the tension on the belt and undo the belt from the belt pulley.
- Install the new belt (order number BA 552 221 200) and tension it correctly. Be aware of the alignment of the motor block! Read "11.4.5 Tightening the V-belt (Tighten belt)" on page 61

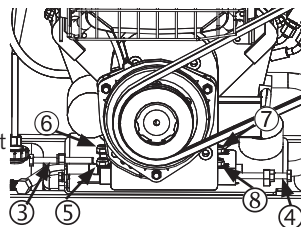

11.4.7 Checking the tension of the drive chain for the feed roller

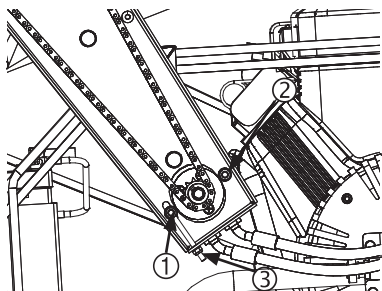

- Remove the chain guard. (read "11.2.2 Removing the chain guard" on page 42)
- Check the tension of the chain
- If the chain is too slack, slacken the bolts (1 & 2) (M8 slw13).
- Tension the chain by tightening the nut (3) on the threaded rod (M6 slw10)



Caution:

The tension on the chain must not be excessive.

- When the chain tension has been adjusted to the correct value, tighten bolts (1 & 2) (M8 slw13).
- Refit the chain guard (read "11.2.2 Removing the chain guard" on page 42)

11.4.8 Checking and adjusting the tracks for correct tension (Cross Country model)

A. Checking for correct tension :

- Lift the track somewhere in the middle between the drive sprocket and the tensioner.
- If you can lift it for about 1 cm from the tensioner, track tension is OK.
- If not, the track needs retensioning.

B. Adjusting the tension

- Loosen the 2 bolts (M10, SW17) first and then remove the guard protecting the track guides.

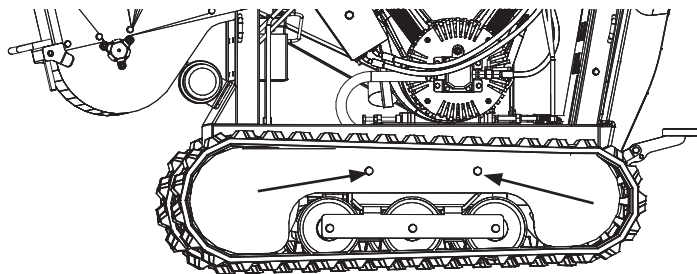

- Unscrew the lock nut (2) (M12 slw19).
- Screw in the central clamping bolt (3) until all the slack is taken up. (M12 slw19)
- Check the tracks for correct tension and turn the clamping bolt (3) further inwards (or outwards if track tension is too high).
- Remember to tighten the lock nut (3) to secure the clamping bolt (2).
- As you go along, thoroughly clean and lubricate the track holder.
- Refit the guard using the 2 bolts using a reverse sequence to that given for removal.

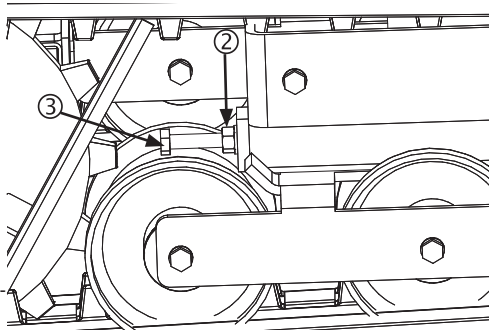

11.4.9 General lubrication (Lubrication)

In view of the fact that the shredders often operate in extreme conditions, Eliet considers it important to use high-quality materials. ELIET therefore recommends the use of special lubricants (from the assembly stage onwards).

The following parts require regular lubrication :

- Pivot points and friction surfaces (read "11.4.9.1 Lubrication of pivot points and friction surfaces" on page 65).
- Grease zerks (read "11.4.9.2 Greasing via the grease zerks fitted" on page 66).
- Bearing (read "11.4.9.3 Lubricating the bearings" on page 67).
- Chains and gears (read "11.4.9.4 Lubricating the chains and the gearwheels" on page 67).



Caution:

Before performing lubrication, make sure to switch off the engine and to remove the key from the ignition switch. Gloves must also be worn during this maintenance.

11.4.9.1 Lubrication of pivot points and friction surfaces

This group includes the following locations on the machine:

- Ground drive control pivot points
- Ball joints of the hydraulic valves
- Nylon sealing plates for the feed roller guides
- Throttle control lever pivot point
- Choke lever
- Quick-closing sieve screening system
- Handles for the maintenance hatch
- Pivot points of the safety guard
- Wheel drive brake guide
- Parking brake foot pedal
- Pivot point of the blow chute
- Hinging point for the deflector flap
- Locking lever for the maintenance hatch

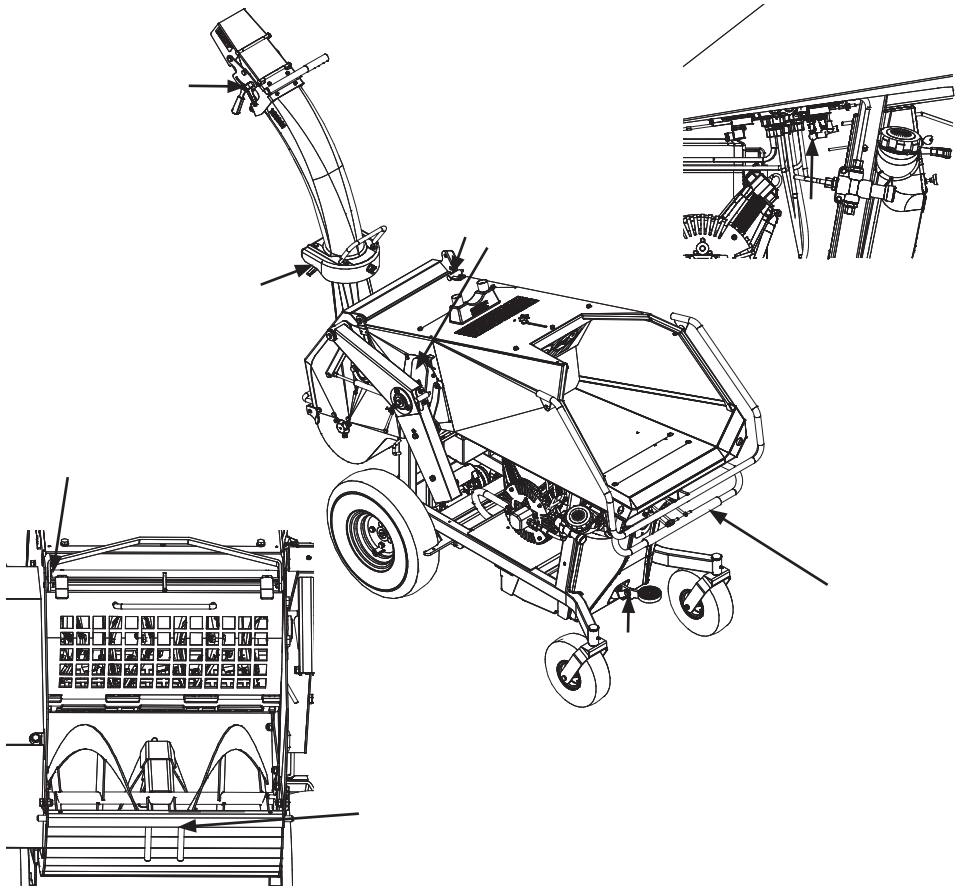

Use the following procedure :

- Whenever possible, disassemble the hinge or the joint.
- Spray some penetrating oil containing molybdenum disulphide onto the frictions surfaces and allow the oil to penetrate.
- Wipe away all traces of old lubricant and dirt.
- In the event of some parts not being accessible, use compressed air to remove all traces of old lubricant and dirt (e.g. in the joints of pivot points).
- When the pivot points are clean, apply new lubricant.
- ELIET recommends Novatio Clearlube as a lubricant for pivot points and ball joints. ELIET would recommend Novatio PFT grease for friction surfaces.
- Wipe away any excess lubricant.

11.4.9.2 Greasing via the grease zerks fitted

This group includes the following locations on the machine:

- Grease zerk on the pivot point of feed roller (1)
- Grease zerks on pivot point of castors (2)
- Grease zerks on the bearings of the castors (3)
- Grease zerks on the track guide bearings (Cross Country model)

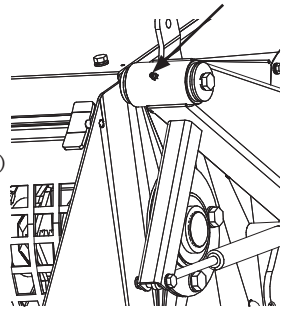
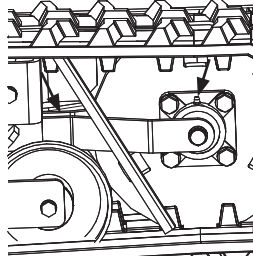
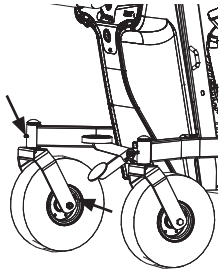

Use the following procedure :

- Clean the grease zerk.
- Using a suitable grease pump, apply new grease.
- ELIET recommends Sunoco Multi Purpose Grease.
- Pumping the grease gun one or two times is sufficient to distribute the grease.
- Wipe away any grease that comes out of the joints.

11.4.9.3 Lubricating the bearings

This group includes the following locations on the machine:

- Bearing of the feed roller
- Bearing of the knife drum
- Bearing of the Axelero™

Use the following procedure :

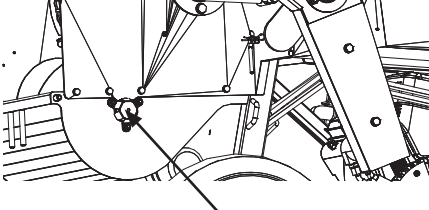
- Spray some penetrating oil containing molybdenum disulphide into the bearing and the area around and allow the oil to penetrate.
 - Wipe away any external dirt.
 - Spray more penetrating oil into the bearing joints.
- 
- Allow the bearing to rotate (possibly by starting the drive that moves the bearing). (CAUTION: make sure that all dangerous zones are adequately shielded).
 - Once again, wiped away any dirt that is forced out by the penetrating oil.
 - Use compressed air to remove all traces of penetrating oil from the bearing and from the bearing joints.
 - Apply new lubricating oil. ELIET recommends Novatio ClearLube as a lubricant.
 - Wipe away any excess lubricant.

11.4.9.4 Lubricating the chains and the gearwheels

This group includes the following locations on the machine: Chain drive of the feed roller.

Use the following procedure :

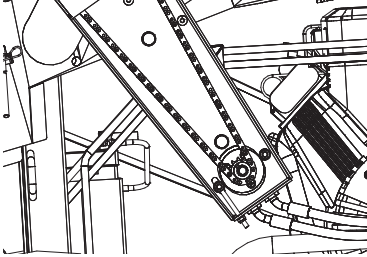
- Remove the guards to expose the drive (read "11.2.2 Removing the chain guard" on page 42).
 - Wipe away all grease in and around the drive.
 - Use penetrating oil containing molybdenum disulphide to dissolve the lubricant.
 - When the drive is clean and all traces of grease and dirt have been removed, you can apply new lubricant.
 - Use a small brush to apply the lubricant to the teeth of the gearwheels. Use Sunoco Multi Purpose Grease or a product of the same quality.
 - It is better to use a thin liquid lubricant that can penetrate into the chains. For this, ELIET recommends Clear Lube lubricant spray from Novatio.
 - After applying the lubricant, the guards are carefully refitted in order to keep out dust and dirt as much as possible.
- 

All these greases are available from your ELIET Dealer.

11.5 Maintenance schedule

The dashboard display will show (top right hand corner) how many hours the machine can run before a certain service must be carried out.

(Next Service: ...h) You can scroll through the maintenance menu using the arrow keys on the dashboard. This list is sorted in ascending order according to maintenance interval. If you exceed the time for a particular service, that software will indicate a maintenance alarm and the Alarm LED will light up. The maintenance menu will now show "Service Now" next to the maintenance timer that has been exceeded.

	Shredding hours	Engine hours
Daily	"11.5.2 Daily maintenance" on page 70	
5		Clean air filter "11.3.4 Cleaning the air filter (Clean air filter)" on page 49
10	Check knives "11.4.1 Checking the blades" on page 52	
25		Engine oil "11.3.2 Engine oil change (Engine Oil)" on page 48
50	Check belt tension "11.4.4 Checking the drive belt for correct tension (Chk Belt Tens.)" on page 60	Oil filter "11.3.3 Changing the oil filter (Oil filter)" on page 48
100	Turn knives "11.4.3 Reversing and renewing the shredding knives (Turn Knives)" on page 55	Lubrication "11.4.9 General lubrication (Lubrication)" on page 64
200	Replace knives "11.4.3 Reversing and renewing the shredding knives (Turn Knives)" on page 55 Replace belts "11.4.6 Changing the belts (Replace Belts)" on page 62	Change air filter "11.3.5 Changing the air filter" on page 49
500		Hydraul. Filter "11.3.8 Changing the hydraulic oil filter (Hydraul. filter)" on page 51 Hydraul. Oil "11.3.7 Changing the hydraulic oil" on page 50

11.5.1 Special maintenance

A. Special maintenance of the blades (chk knife bolts)

After inserting the blades into the rotor, the blades will bed-in after a brief period. This can cause the tension on the bolts to decrease, with the risk that the blades may become dislodged between the blade plates. This can cause irrevocable fatigue failure of the blade shaft. This must be prevented by scheduling extra maintenance after the brief bedding-in period.

When: Within the first five operating hours after starting up the new machine
 Within the first 5 hours after rotating the blades
 Within the first 5 hours after changing the blades

What: Check all blade bolts for correct torque loading and retighten if considered necessary. (torque loading read "16.2 List of torques" on page 78)



Warning:

Failure to perform this special maintenance will compromise the safety of the operators and bystanders and can cause serious damage to the machine.

B. Special maintenance of the drive belt (Tighten Belt)

The belt that transfers the power from the engine to the blade shaft is long. During the bedding-in period, the belt will stretch naturally to a certain extent. This stretching will reduce the belt tension. Using the machine when the belt tension is too low will cause the belt to slip, twist or wear down. These three possibilities have a detrimental effect on a new belt.

When: Within the first 10 operating hours after starting up the new machine
 Within the first 10 hours after changing a belt

What: Check the belt tension (read "11.4.4 Checking the drive belt for correct tension (Chk Belt Tens.)" on page 60)

C. Special service in relation to replacing the motor oil (Engine Oil)

All wear-and-tear particles and manufacturing dirt that is created or is still present in the motor will be captured by the oil filter. The fine particles that are not filtered out of the oil will be cleaned by this special service.

When: Within the first 5 engine hours after starting up the new machine

What: Change engine oil (read "11.3.2 Engine oil change (Engine Oil)" on page 48)

11.5.2 Daily maintenance



Caution:

Before performing any maintenance, stop the engine and remove the key from the ignition switch. Wear suitable clothing.

- Check for signs of leakage.
- Open the shredding chamber (read "11.2.5 Opening the shredding chamber" on page 43).
- Clean the machine (read "9.7 Cleaning the machine" on page 36).
- Inspect the blades, and if necessary, sharpen them (read "11.4.1 Checking the blades" on page 52).
- Check the machine for signs of abnormal wear or fractures.
- Check the Axelero™ for signs of abnormal wear or fractures.
- Check the bolts for correct tightness. (Blades, wheels, bearings, engine,...).
- Check the oil level in the engine crankcase (read "11.3.1 Checking the oil level in the engine crankcase + refilling" on page 47).

11.5.3 Maintenance after 5 hours



Caution:

Before performing any maintenance, stop the engine and remove the key from the ignition switch. Wear suitable clothing.

- Daily maintenance (read "11.5.2 Daily maintenance" on page 70).
- Clean the air filter (read "11.3.4 Cleaning the air filter (Clean air filter)" on page 49).

11.5.4 Maintenance after 10 hours



Caution:

Before performing any maintenance, stop the engine and remove the key from the ignition switch. Wear suitable clothing.

- Daily maintenance (read "11.5.2 Daily maintenance" on page 70).
- Inspect the blades, and if necessary, sharpen them (read "11.4.1 Checking the blades" on page 52).

11.5.5 Maintenance after 25 hours



Caution:

Before performing any maintenance, stop the engine and remove the key from the ignition switch. Wear suitable clothing.

- Daily maintenance (read “11.5.2 Daily maintenance” on page 70).
- Change the engine oil (read “11.3.2 Engine oil change (Engine Oil)” on page 48).

11.5.6 Maintenance after 50 hours



Caution:

Before performing any maintenance, stop the engine and remove the key from the ignition switch. Wear suitable clothing.

- Daily maintenance (read “11.5.2 Daily maintenance” on page 70).
- Check the belt tension (read “11.4.4 Checking the drive belt for correct tension (Chk Belt Tens.)” on page 60).
- Reverse blades (read “11.4.3 Reversing and renewing the shredding knives (Turn Knives)” on page 55).
- Check the chain tension and, if necessary, adjust the tension. (read “11.4.7 Checking the tension of the drive chain for the feed roller” on page 63).
- General lubrication (read “11.4.9 General lubrication (Lubrication)” on page 64).

11.5.7 Maintenance after 100 hours (or six-monthly)



Caution:

Before performing any maintenance, stop the engine and remove the key from the ignition switch. Wear suitable clothing.

- Daily maintenance (read “11.5.2 Daily maintenance” on page 70).
- Maintenance after 50 hours (read “11.5.6 Maintenance after 50 hours” on page 71).
- Reverse RESIST™ blades (read “11.4.3 Reversing and renewing the shredding knives (Turn Knives)” on page 55).
- Replace the oil filter (read “11.3.3 Changing the oil filter (Oil filter)” on page 48).

11.5.8 Maintenance after 200 hours (or annually)



Caution:

Before performing any maintenance, stop the engine and remove the key from the ignition switch. Wear suitable clothing.

- Maintenance after 100 hours (read “11.5.7 Maintenance after 100 hours (or six-monthly)” on page 71).
- Air filter change (read “11.3.4 Cleaning the air filter (Clean air filter)” on page 49).
- Change RESIST™ blades (read “11.4.3 Reversing and renewing the shredding knives (Turn Knives)” on page 55).
- Changing the hydraulic oil + replacing filter (read “11.3.8 Changing the hydraulic oil filter (Hydraul. filter)” on page 51 en “” op pagina 51).
- Replacing air filter (read “11.3.5 Changing the air filter” on page 49).
- Changing the engine fuel filter (read “11.3.6 Changing the engine fuel filter (Oil filter)” on page 50).
- Changing spark plugs (read the engine manual).
- Checking the tracks (read “11.4.8 Checking and adjusting the tracks for correct tension (Cross Country model)” on page 63).

After performing maintenance or a repair, make sure that you correctly refit ALL guards.

12. Winterizing the machine



- Clean the machine (read “11.5.2 Daily maintenance” on page 70).
- Store the machine in a dry place that is protected from rain, and if necessary, cover it with a tarpaulin.
- Always allow the machine to cool down before storage.
- If the machine is to be stored outside, it must be well protected with a tarpaulin. Ensure that water does not directly fall onto the machine. At ELIET, we strongly recommend that the machine is stored at a location that is well protected from the weather, etc.
- When winterizing the machine for long periods, it is recommended to perform the following steps:
 - Perform a 50-hour overhaul. (read “11.5.6 Maintenance after 50 hours” on page 71).
 - Check all nuts and bolts for correct tightness, and where necessary, retighten them.
 - Places where the paint coating is damaged are repainted or covered with grease in order to prevent rust. Original ELIET paints in the same colour are available from your ELIET Dealer (article no.: BX 043.200.400).

13. Options

13.1 Sieve screening

You can choose from a variety of sieves that can be changed easily.
The different types are:

1. MA 029 001 007 : Lower sieve honeycomb 30mm
2. MA 029 001 008 : Upper sieve honeycomb 30mm
3. MA 029 001 009 : Lower sieve honeycomb 35mm
4. MA 029 001 010 : Upper sieve honeycomb 35mm
5. MA 029 001 011 : Sieve for moist material
6. MA 029 001 013 : Sieve palm leaf

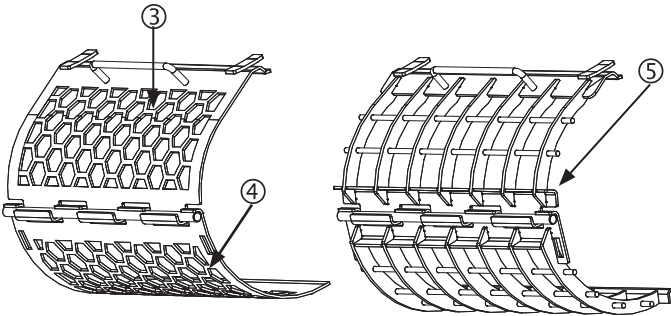
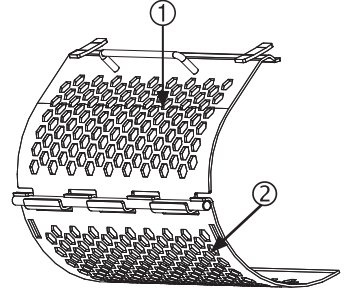

Fitting the sieve

- Open the Axelero™ chamber (read "11.2.4 Opening the Axelero™ chamber" on page 42).
- Open the shredding chamber (read "11.2.5 Opening the shredding chamber" on pagina 43)

You can combine the upper and lower sieves with one another in order to obtain the chipping size that you would like.

14. Equipment specifications

	SUPER PROF	SUPER PROF CROSS COUNTRY	SUPER PROF ON ROAD
Engine		B&S Vanguard	
Engine start system		electric	
Type		gasoline	
Number of cylinders		2	
Cylinder capacity (cc)		570	
Power kW/Pk DIN (r/min)		13,4 / 18 (3400)	
Engine cooling		air cooled	
Fuel tank capacity		18 L	
Processable timber diameter		130 mm	
Return (wheelbarrows/hour)		6 m ³ ships/hour	
shaft blades		6 discs, 24 blades Eliet Resist™/ 8 (10 Super Prof Max)	
Cutting frequency		5000 chops/min	
Transmission		Belt XPA 2120 x 2 Powerband	
Clutch		elektromagnetisch + remfunctie	
Feeding Support		Hydraulische invoerwals Ø 156 mm	
Hydraulic oil tank		13 L	
Battery		12V	
Power control		Eliet ABM (anti-blocking systeem)	
Ergonomic & safe input height		invoerhoogte 1000mm / i nvoeropening 500mm x 700mm	
Output		calibrating sieve 25x25mm / Axelero™ Ø 300mm	
		output height 2000mm / throwing distance 0,5m<>15m	
		ejector foldable for transport (H: 1450mm)	
Compact design (LxWxH)	2000x835x1450mm low center of gravity	2000x890x1450 mm	3000x1500x1450 mm
sound level	116 dB(A)	116 dB(A)	116 dB(A)
Wheel traction	2 x hydraulic wheelengines (100cc)	2 x hydraulic wheelengines (250cc)	
Wheels	front: 4.00 - 4 pneumatic tire / back: 6.00 x 9 pneumatic tire	caterpillars 180 x 72 x 37 cm	
Weight	437 kg	502 kg	495 kg
Eco-Eye™ system	optional	optional	optional
Speed control infeed roller	optional	optional	optional
Agricultural tyres	optional	-	-
Calibrating sieve 35 x 35 mm	optional	optional	optional
Sieve for moist products	optional	optional	optional

15. EC Declaration of Conformity



Machine Super Prof

model number:	MA 029 040 113	SUPER PROF + ABM + ZR
model number:	MA 029 040 117	SUPER PROF MAX + ABM+ZR
model number:	MA 029 050 113	SUPER PROF Cross Country
model number:	MA 029 050 117	SUPER PROF MAX Cross Country
model number:	MA 029 070 113	SUPER PROF On Road
model number:	MA 029 070 117	SUPER PROF MAX On Road

The previously mentioned machine has been designed and manufactured to comply with the following European CE regulations :

EN 13525: Forestry machinery : wood chippers - safety

ELIET mfg. cy. hereby declares that after performing a hazard analysis, it is fully aware of the potential hazards and risks associated with the machine. In this knowledge, the necessary steps have been taken in line with Machine Directive 2006/42/EC in order to ensure absolute operator safety for the operator, when the machine is used correctly.

The value of the measured sound power level and the guaranteed sound power level were obtained according the procedures set forward in the directive 2000/14/EG annex III/B clause 50 and directive EN 13525..

Measured sound power level LwA : 115 dB(A)

Guaranteed A-weighted sound power level : 116 dB(A)

Date: 01/01/2015

Signature:

A handwritten signature in black ink, appearing to read 'Frederic LIETAER'. The signature is stylized and written over a light grey rectangular background.

Frederic LIETAER
CEO ELIET EUROPE NV

ELIET EUROPE NV
Diesveldstraat 2
B - 8553 Otegem (Belgique)
T. +32 56 77 70 88 - F. +32 56 77 52 13
E. info@eliet.eu - W. www.eliet.eu

16. Appendix

16.1 Technical specifications of the lubricants and fuel

Engine oil	Synthetic oil SF, SG, SH, SJ
Viscosity	SAE 5 W 30 / SAE 10 W-30
Capacity of engine crankcase	1.7 L

Fuel	Unleaded petrol (gasoline)
Minimum RON	85
Capacity of fuel tank	18 L

Hydraulic oil	Conforms to DIN 51524 Part 3 HVLP
Viscosity	ISO VG 46 cSt
Capacity of hydraulic system	13 L

Brands	
SUNOCO	Sunvis 846 WR HV
ELF	Hydrelf DS 46
SHELL	Tellus TD 46
TOTAL	Equivis ZS 46
CASTROL	Anvol WG 46
TEXACO	Rando HDZ 46
MOBIL	DTE 15 M
ESSO	Univis N 46

Lubricant for bearings	NOVATIO CLEAR LUBE
Lubricant for pivot point	NOVATIO CLEAR LUBE
Lubricant for friction surfaces	NOVATIO PTFE OIL
Lubricant for chain transmission	NOVATIO CLEAR LUBE
Lubricant for grease zerks	SUNOCO MULTI PURPOSE LR EP2

16.2 List of torques

Bolt head according to DIN 931,912 etc.	Strength	
	8.8	10.9
	Thread	
Normal thread	M4	4,4
	M5	8,7
	M6	15
	M8	36
	M10	72
	M12	125
	M14	200
	M16	310
	M18	430
	M20	610
	M22	820
	M24	1050
	M27	1550
	M30	2100
Fine thread	M8 x 1	35
	M10 x 1,25	69
	M12 x 1,5	130
	M14 x 1,5	215
	M16 x 1,5	330
	M18 x 1,5	485
	M20 x 1,5	680
	M22 x 1,5	900
	M24 x 2	1150
	M27 x 2	1650
M30 x 2	2350	

(with friction factor $\leftrightarrow = 0.14$)

16.3 Troubleshooting - resolving problems

The troubleshooting page on the dashboard indicates both electrical and mechanical faults that could pose a risk for both operator and machine.

If there is a fault, the Alarm LED will light up, the LCD screen back-light will blink and an error message will appear on the display.

Pressing the 'Alarm' button will show the troubleshooting page; if there are multiple problems, the arrow keys can be used to scroll through the list.

The following faults could occur:

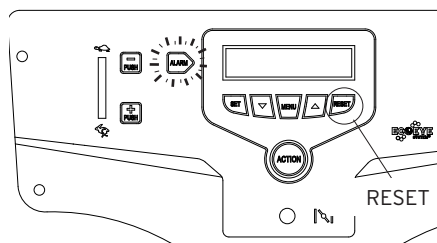

16.3.1 F00: Oil Press. Low

If this error message is shown on the display, the oil pressure in the motor is low. Check the oil level of the motor and replenish if necessary. (read "11.3.1 Checking the oil level in the engine crankcase + refilling" on page 47)

After carrying out the necessary repair to resolve the fault, the Reset button in the troubleshooting menu can be pushed in order to remove the error message.

16.3.2 F01: Safety Cover

If this error message is shown on the display, the maintenance hatch is not correctly closed.

This maintenance hatch is equipped with a safety contact (1) which ensures that the machine will not start if it is not correctly closed.

Open the Axelero™ chamber and shut it correctly. (read "11.2.4 Opening the Axelero™ chamber" on page 42)

Push the Reset button in the troubleshooting menu to remove this error message.

If this error message does not disappear, there is a fault in the safety contact. Order a new part from your distributor with order number BE 120 030 020

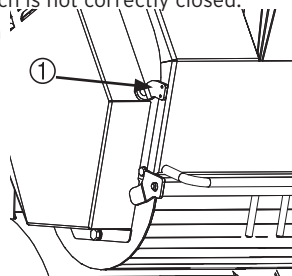

16.3.3 F02: Oil Pr. sensor

If this error message is shown on the display, there is a problem with the oil pressure sensor.

When starting the machine, a check is performed on whether this sensor is working.

If you see this error message, you must contact your distributor.

16.3.4 F03: Short Clutch

This error message indicates that there is a short circuit on the electrically driven coupling. Check to ensure that the counter is still properly connected to the electric coupling. Check all electrical wiring and sockets on the coupling.

16.3.5 F04: Wiring Clutch

The electrical wiring is faulty; check the wiring and sockets for breakages.

16.3.6 F05: Short FEED FWD

If this error message is shown on the display, there is a short circuit to the electrical wiring and/or output sockets. Check the wiring and the sockets that run from the supply button to the dashboard.

16.3.7 F06: Wiring FEED FWD

If this error message is shown on the display, there is a wiring breakage to the electrical wiring and/or supply sockets. Check the wiring and the sockets that run from the supply button to the dashboard.

16.3.8 F07: Short FEED REV

If this error message is shown on the display, there is a short circuit to the electrical wiring and/or output sockets. Check the wiring and the sockets that run from the output button to the dashboard.

16.3.9 F08: Wiring FEED REV

If this error message is shown on the display, there is a wiring breakage to the electrical wiring and/or supply sockets. Check the wiring and the sockets that run from the output button to the dashboard.

16.3.10 F09: Short THROTTLE

This error message indicates that there is a short circuit on the electrical wiring from the thrust lever. Check the wiring and sockets to the thrust lever.

16.3.11 F10: Wiring THROTTLE

This error message indicates that there is a wiring breakage on the electrical wiring from the thrust lever. Check the wiring and sockets to the thrust lever.

16.4 Dashboard warnings

16.4.1 W00: Safety Bar

The safety-stop-bracket is pushed in. Pull this back out order to activate the blade axle.

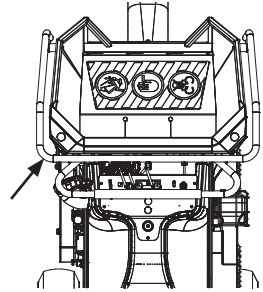

16.4.2 W01: AntiBlock Motor

When activating the motor's ABM system, this warning will appear on the dashboard

16.4.3 W02: Speed Up Engine

The revolutions of the motor are insufficient for chipping. Set the machine to run at full gas for chipping.

16.4.4 W03: Activate Blades

This message indicates that the blades are not engaged. Before putting wood into the machine, the blades must be engaged. Push the Action button to do so.

16.4.5 W04: Load Too High

If the rotor blocks, the electrical coupling will disengage and the feed roller will turn backwards in order to push out wood from the blade axle. Check the blade axle for blockages before opening the shredder chamber. (read "11.2.5 Opening the shredding chamber" on page 43)

16.4.6 W05: Start failed

If starting takes too long, the starter motor will automatically be interrupted. First check the fuel level and check "9.6.1 Before starting work" on page 29 to ensure that all of the points have been fulfilled in order to start the machine.

16.5 Warranty-conditions

Dear Customer,

We thank you for purchasing an ELIET product. Congratulations on your purchase of this machine which is sure to meet your expectations and needs over the coming years. At Eliet, we do everything to ensure that our products function correctly. That is why your product qualifies for a two year guarantee.

What is warranty ?

At Eliet, we have strict quality rules on designing and manufacturing products. The priorities given by these rules are to guarantee a long service life and permanent safety. That is why at Eliet, we are willing to repair at no charge hidden defects or faults during the whole run-in period (aka the warranty period), provided the prescribed procedure is followed.

Warranty conditions

ELIET's warranty obligations for new machines is governed by the following conditions.

I. Warranty period

The warranty period starts the day the dealer delivers the machine to the customer (maximum one week after the purchase) and expires :

- after two years of private use.
- after twelve months or 100 running hours of rental use.
- after twelve months or 100 running hours in semi-professional or in professional use.

To be eligible to obtain warranty the customer is invited to register the newly purchased machine with ELIET. You should complete the registration online on Eliet's website : www.eliet.eu.

II. What is covered by the warranty ?

- Wear items are not covered by the warranty conditions : (such as blades, bearings, belts, chains, gearwheels, tyres, bulbs, fuses, etc).
- If failures are found to be caused by improper use, neglect or consequential damages by an external source (fall, chippings, foreign objects, accident).
- If failures are found to be caused by improper maintenance of the machine, that is not in accordance with the prescribed periodic maintenance.
- When a defect is caused by improper repair made by anyone other than an authorized ELIET dealer or after using not genuine Eliet service parts.
- When the defect is caused by making improper changes to the original design of the machine.
- When the fault develops when the machine has been used not in accordance with the instructions contained within this manual.
- When the prescribed warranty procedure has not been adhered to or when the warranty period has expired.
- For all problems relating to the motor, please contact an authorized service centre of the

engine manufacturer.

III. Procedure

- **Step 1 :** On the date of purchase, the customer should register his/her purchase online by completing the registration card at www.elieta.eu.
- **Step 2:** In the event of a defect becoming apparent, the customer shall have this verified by the authorized ELIET dealer. If the dealer feels that there is a factory defect, the dealer may invoke the warranty, under the terms specified.
- **Step 3 :** Every warranty application must be accompanied by a fully completed official application form. Copies of this warranty application are available to dealers at ELIET or even at an importer/agent.
- **Step 4 :**The dealer then orders the parts needed to perform the repairs. Next, the dealer faxes the order form together with the completed warranty form .
- **Step 5 :** The warranty form should be stapled to the purchase invoice and mailed to ELIET or an importer/agent of ELIET.
- **Step 6 :** ELIET will send the parts ordered to the dealer under the regular delivery and payment conditions.
- **Step 7 :** The defective part will be examined by the technical department first prior to approving or rejecting the warranty. ELIET reserve the right to solely decide whether or not the customer has complied with the conditions for the validity of this guarantee, i.e. 1 year or 2 years. Faulty components shall become the property of ELIET.
- **Step 8 :** When a warranty claim is found to be valid, ELIET will credit the warranty parts. Customers shall never be entitled to apply for a refund of labour costs.

IV. In case of damage caused by transport

- All goods are supplied ex factory. Transport risks are borne by the customer. It follows, that ELIET highly recommend to check the goods for damage on arrival.
- Any damage found should be stated on the delivery form before signing. Make sure the driver of the haulage company puts his signature next to the damage on your copy.
- In the absence of a written and signed declaration on the delivery form, the insurance of the haulage company will not accept any liability.
- Damages can be claimed from the hauler using a copy of the delivery form and a covering letter stating your complaint.
- The damaged machine should be kept in its original condition until the hauler's insurer has performed any examination.



Registratie machine

Contactgegevens

Bedrijf

Voornaam

Naam

Adres

Postcode

Gemeente

Land

Telefoon (incl. landcode)

Fax

E-mail

BTW nr.

Machine

Machine *Uw machine niet gevonden in deze lijst? Neem dan contact op met ons op +32 56 77 70 88 of info@eliet.eu*

Serienummer:

Datum aankoop

Algemene info

Deze machine zal voornamelijk gebruikt worden voor:

- Particulier gebruik
 Professioneel gebruik
 Verhuur

Ik heb een tuin van:

- < 50 m²
 50 - 200 m²
 200 - 1000 m²
 1000 - 5000 m²
 > 5000m²

Naam dealer

Heeft de dealer u voldoende uitleg gegeven over de werking van de machine?

- Ja Nee

Heeft de dealer het onderhoudsschema met u overlopen?

- Ja Nee

Hebt u de gebruiksaanwijzing goed ontvangen die bij de machine geleverd werd?

- Ja Nee

Ik geef toestemming om mijn gegevens te gebruiken voor administratieve doeleinden

